

*Equipment for Commercial Vehicles*



**TRANSIT CONNECT  
PACKAGE CATALOG**



ACCELERATE YOUR  
BUSINESS WITH  
**RANGER  
QUICKSHIP**



**RANGER**  
DESIGN

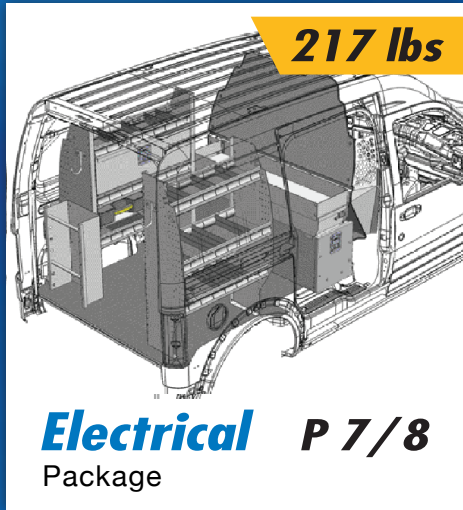
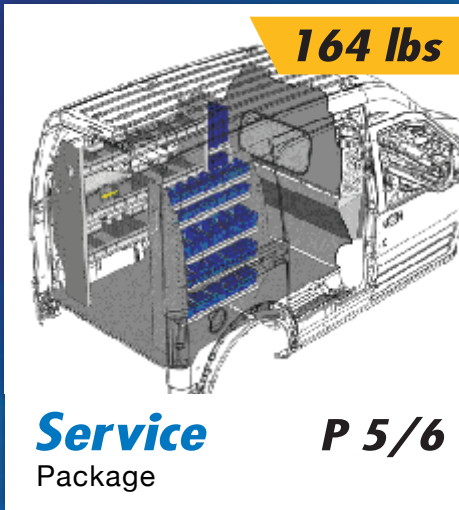
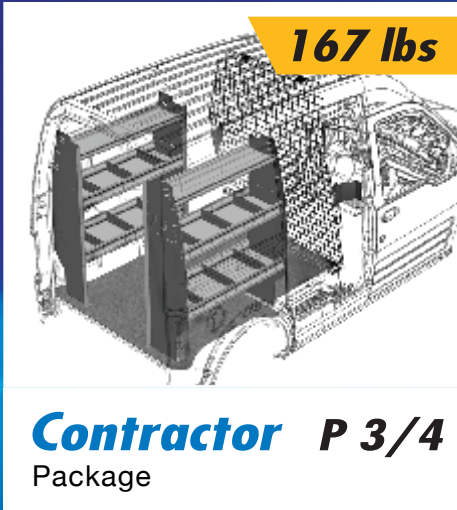

In 1988 a small family business with a passion for innovation and speed of service began to build equipment for commercial vehicles. Now with factories in Rochester, NY and Montreal Canada, and a strong network of dealers across North America, the same passion still drives the company today.

In our modern fast-paced world, Ranger combines old-fashioned service with state of the art technology to bring you consistent quality and strength to meet the toughest demands. This is why more Tradesmen and Fleets across the nation are turning to Ranger solutions for shelving units, storage systems, partitions and ladder racks to answer their unique needs. Contact us today and experience the Ranger difference yourself!

- The Ranger Team



1

**Shelving**



**Ladder Racks**



**Fold-Away Shelving**

**254 lbs**

**HVAC**  
Package **P 9/10**



**125 lbs**

**Contractor P 11/12**  
Package

**138 lbs**

**Delivery P 13/14**  
Package

## RANGER DESIGN PROVIDES THE POWER OF 24-HOUR SHIPPING

to get you on the road to success faster than ever! Ranger **QUICKSHIP**  guarantees that selected packages with the **QUICKSHIP**  will ship within 24 hours if ordered before 1PM. Visit our website [www.rangerquickship.com](http://www.rangerquickship.com) for ordering details or contact one of our Customer Service representatives at [cs@rangerdesigninc.com](mailto:cs@rangerdesigninc.com).



### Quiet

A peaceful ride with no rattles



### Quick

Fastest lead times in the industry



### Tough

For the toughest



### Payload

Engineered to save weight



**Bin Shelving**



**Drawer Systems**



**Partitions**

# STEEL CONTRACTOR Package



**TOUGH  
JOBS  
TOUGH  
TOOLS**

## **Optional**

1510-FC Standard ladder rack  
400 lbs capacity

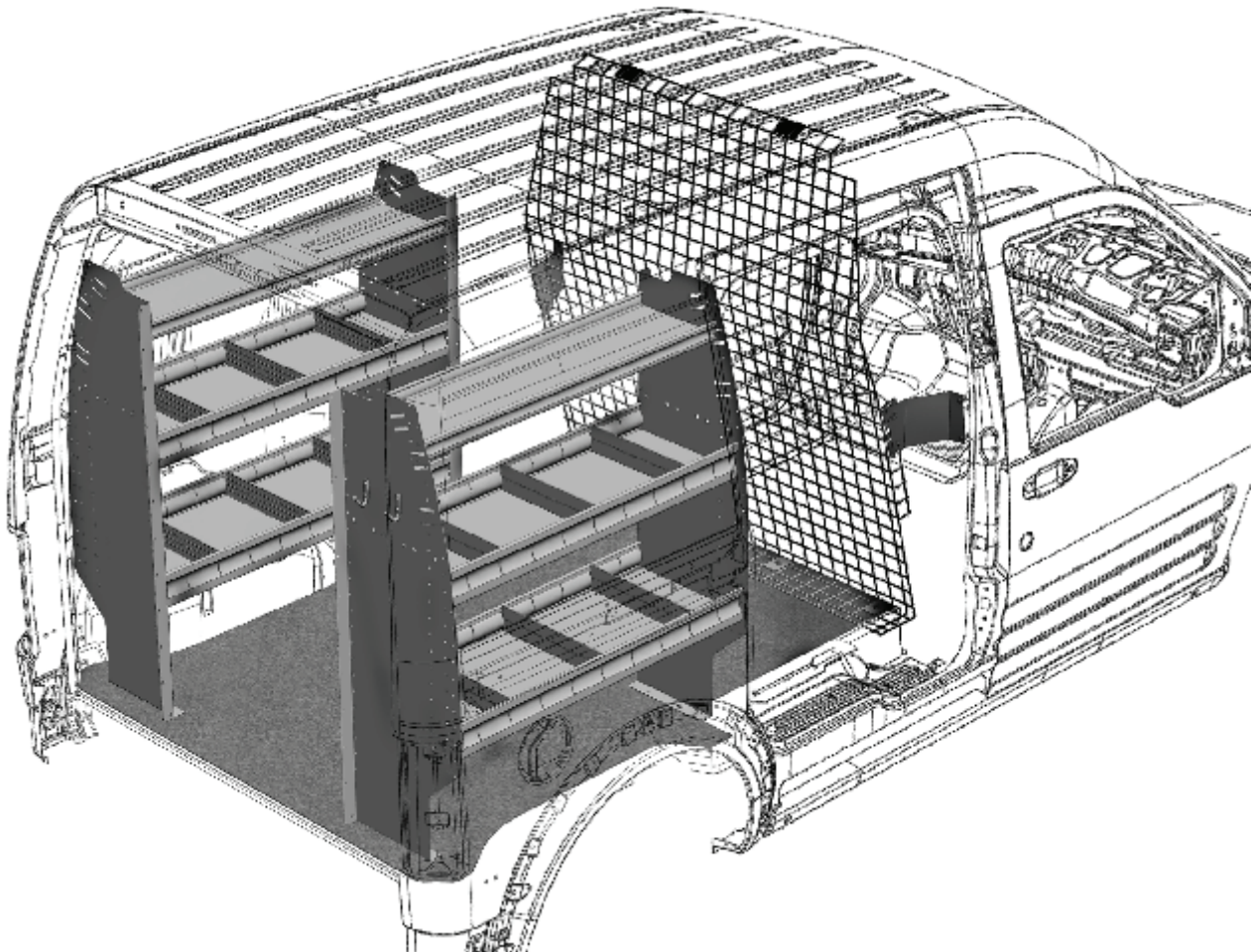
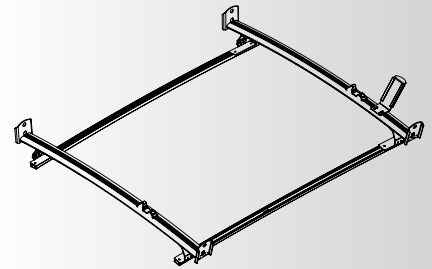

## Z05-V Contractor Package, mesh partition

**RANGER**  
FLEETLINE

- 1 **C13-V** Contoured wire mesh partition
- 2 **F38-A** Contoured shelving unit, 38"w
- 2 **Y30-C** Coat Hook



THIS PACKAGE IS  
**QUICK SHIP**

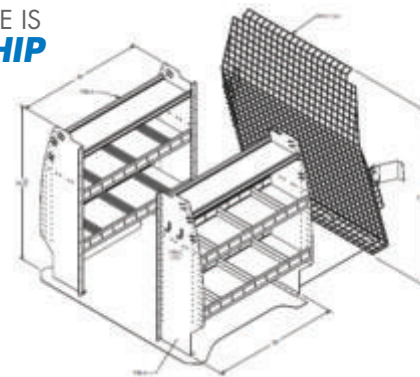

## Z10-V Contractor Package

**RANGER**  
FLEETLINE

- 1 **C10-V** Contoured partition
- 1 **F38-A** Contoured shelving unit, 38"w
- 1 **L38-A** Contoured shelving unit, 38"w
- 2 **Y30-C** Coat Hook



THIS PACKAGE IS  
**QUICK SHIP**

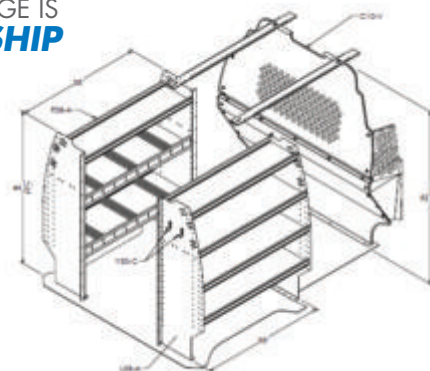

## Z30-V Contractor Package upgrade kit

**RANGER**  
FLEETLINE

- 1 **Y11-D** Fleetline locking door
- 1 **6070** Fixed hook
- 1 **Y31-A** 3 Slot paper holder
- 12 **Y35-B** Medium bin



THIS PACKAGE IS  
**QUICK SHIP**

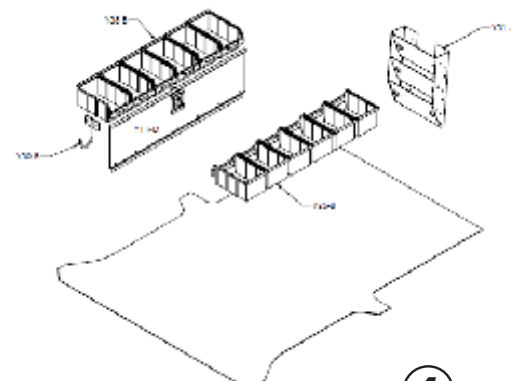

# ALUMINUM **SERVICE** Package

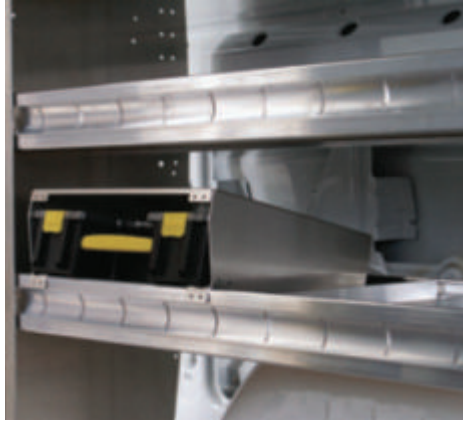

## **Optional**

1505-FC Cargo Rack  
480 lbs capacity

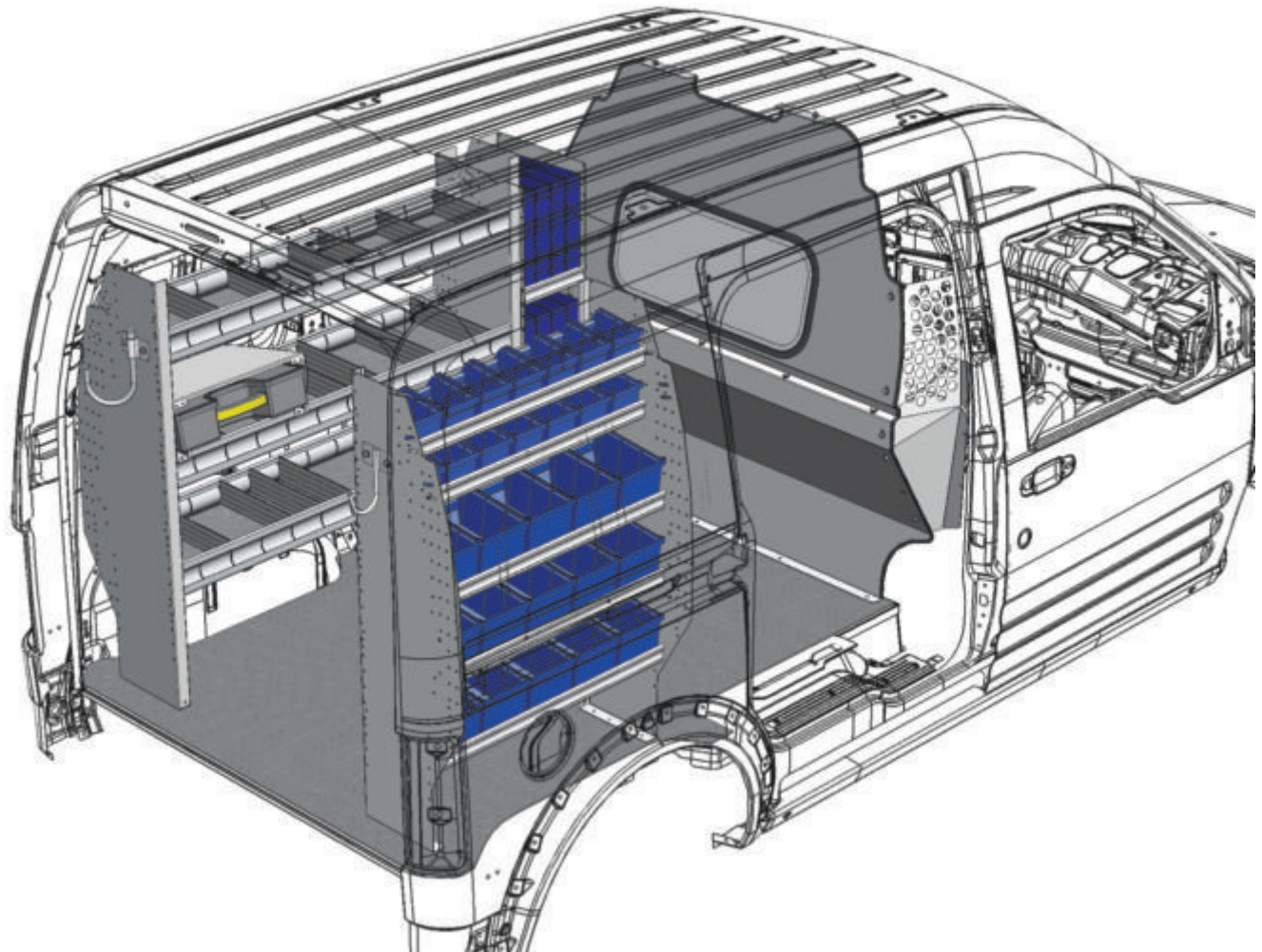

## C316 Base Service Package

**RANGER**  
PROLINE

- 1 **3020-FC** Window Partition

---

- 1 **BA30** 30" bin unit with 5 shelves

---

- 1 **SA30-3** 30" shelf unit with 3 shelves

---

- 1 **5070** Partskeeper

---

- 1 **6070** Fixed Hook

---

- 1 **6072** Swivel Hook

---



THIS PACKAGE IS  
**QUICK SHIP**

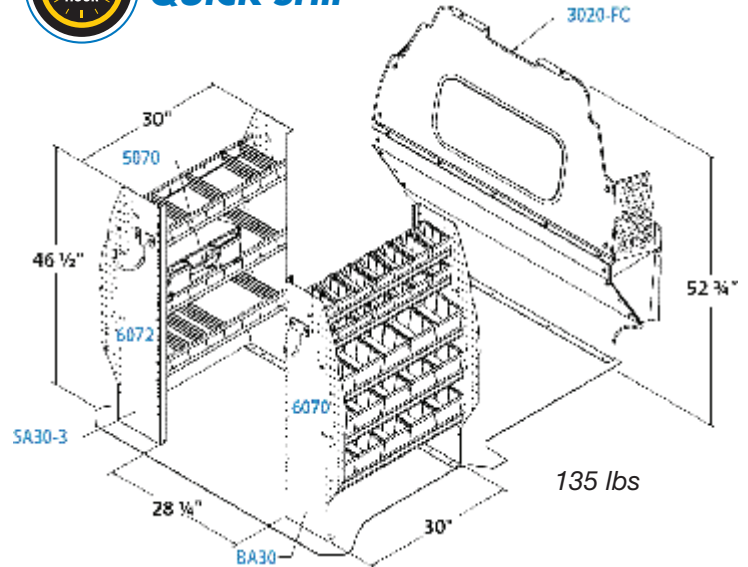

## C216 Deluxe Service Package

**RANGER**  
PROLINE

- 1 **3020-FC** Window Partition

---

- 1 **BA30** 30" bin unit with 5 shelves

---

- 1 **SA48-3** 48" shelf unit with 3 shelves

---

- 1 **5070** Partskeeper

---

- 1 **6070** Fixed Hook

---

- 1 **6072** Swivel Hook

---

- 1 **7109** Bookshelf

---



THIS PACKAGE IS  
**QUICK SHIP**

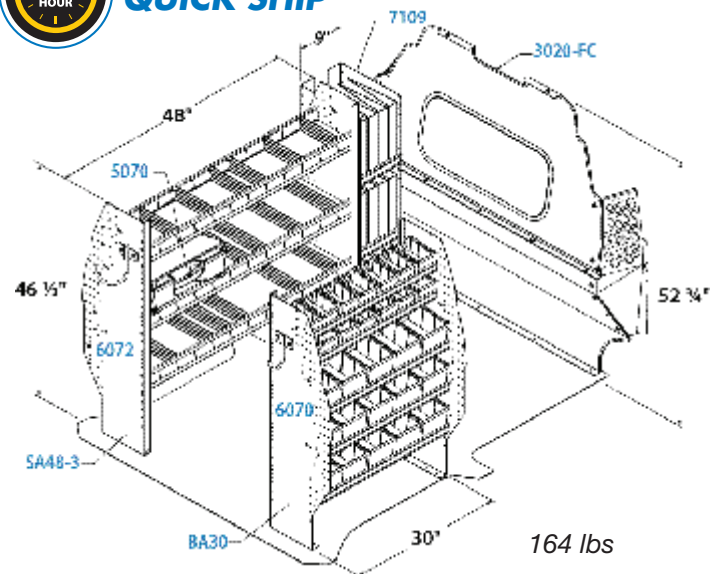

# ALUMINUM ELECTRICAL Package

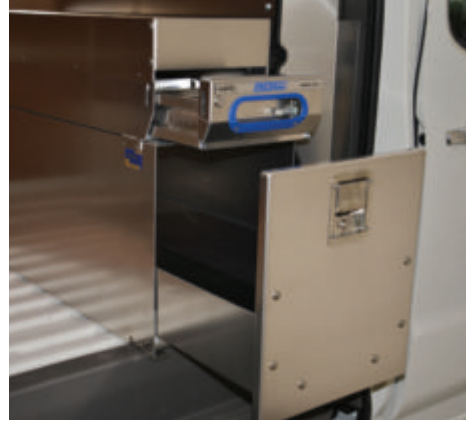

## Optional

1530-FC Double clamp ladder rack,  
shown with 2 extension ladders

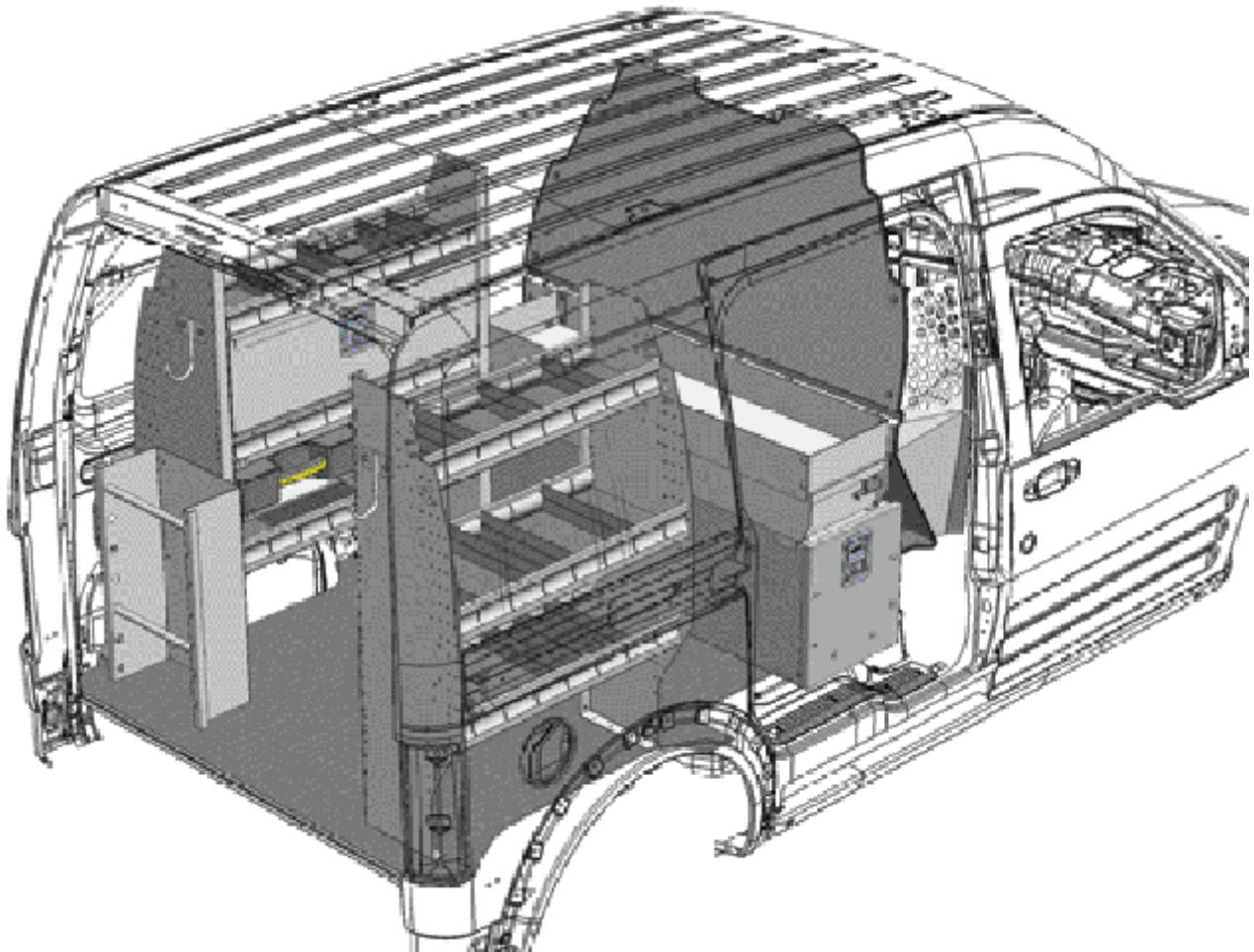
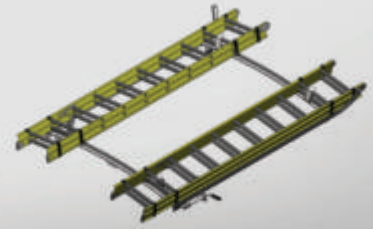



## C311 Base Electrical Package

**RANGER**  
PROLINE

- |   |                |                               |
|---|----------------|-------------------------------|
| 1 | <b>3010-FC</b> | Safety Partition              |
| 1 | <b>SA30-3</b>  | 30" shelf unit with 3 shelves |
| 1 | <b>SA36-3</b>  | 36" shelf unit with 3 shelves |
| 1 | <b>5076</b>    | Partskeeper                   |
| 1 | <b>6070</b>    | Fixed Hook                    |
| 1 | <b>6072</b>    | Swivel Hook                   |
| 1 | <b>7124</b>    | Reel Holder                   |
| 1 | <b>7728</b>    | Locking Door                  |

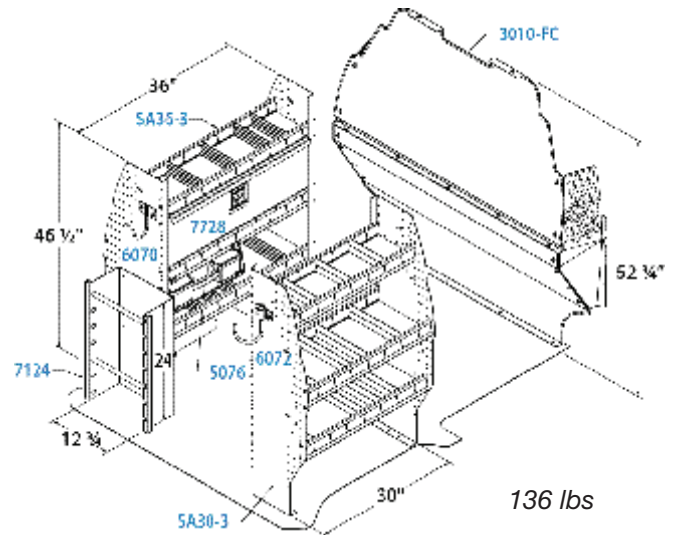

## C211 Deluxe Electrical Package

**RANGER**  
PROLINE

- |   |                |                                      |
|---|----------------|--------------------------------------|
| 1 | <b>3010-FC</b> | Contoured safety partition, aluminum |
| 1 | <b>SA30-3</b>  | Contoured shelf unit, aluminum       |
| 1 | <b>SA36-3</b>  | Partslider, aluminum, 150 lbs cap.   |
| 1 | <b>5010</b>    | Tool drawer, aluminum, 320 lbs cap.  |
| 1 | <b>5020</b>    | Top edge, aluminum                   |
| 1 | <b>5048</b>    | Partskeeper carry case w/holder      |
| 1 | <b>5070</b>    | Contoured bin unit, aluminum         |
| 1 | <b>6070</b>    | Hook, aluminum, 3" opening           |
| 1 | <b>6072</b>    | Swivel hook, aluminum, 4" opening    |
| 1 | <b>7124</b>    | Large aluminum movable hook          |
| 1 | <b>7728</b>    | Reel holder with two 5/8" dia rods   |

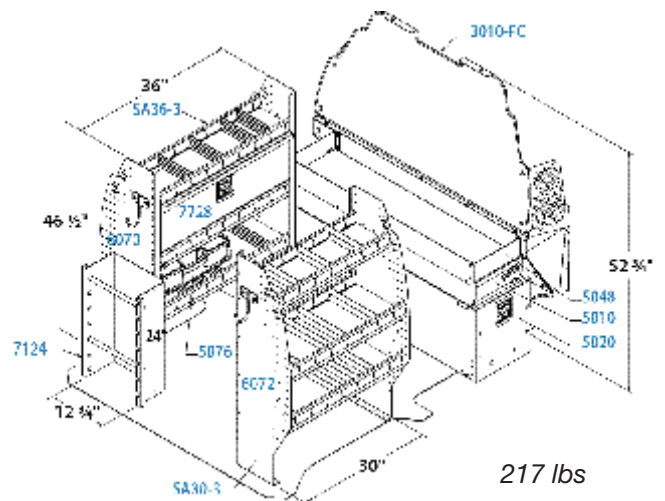

# ALUMINUM HVAC Package

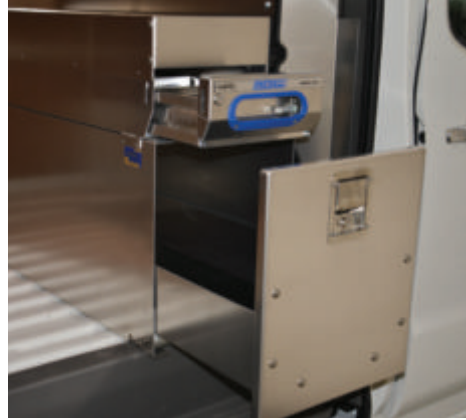

## Optional

1525-FC Combination Ladder Rack  
400 lbs capacity



Base and Deluxe Packages hold up to four 30 lbs bottles and two 50 lbs bottles.

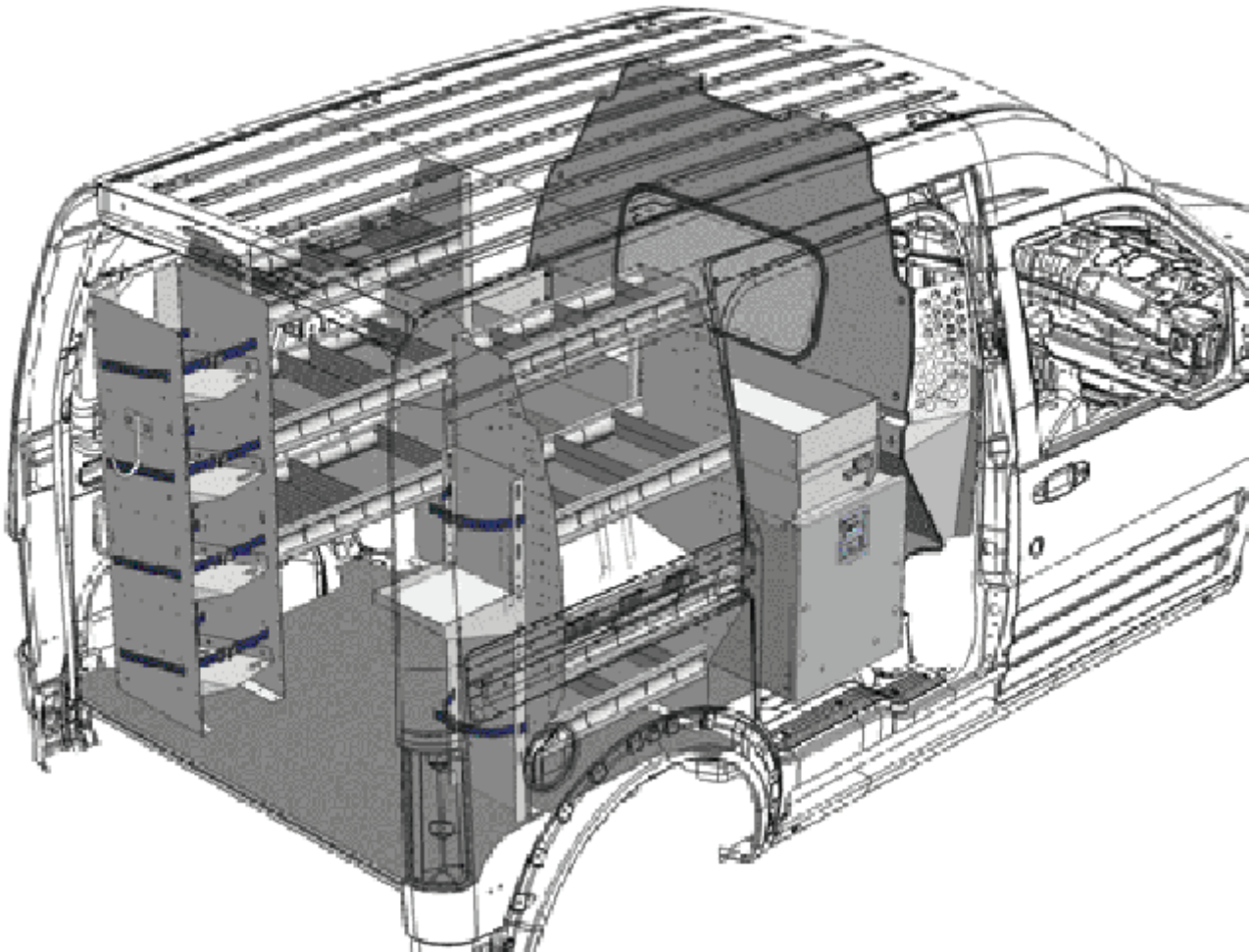

## C312 Base HVAC Package

**RANGER**  
PROLINE

- 1 **3020-FC** Window Partition

---

- 1 **SA24-4** 24" shelf unit with 4 shelves

---

- 1 **SA30-3** 30" shelf unit with 3 shelves

---

- 1 **6007** 4 Tier Freon Rack for small bottles

---

- 1 **6010** Two Level Bottle Holder

---

- 1 **6070** Fixed Hook

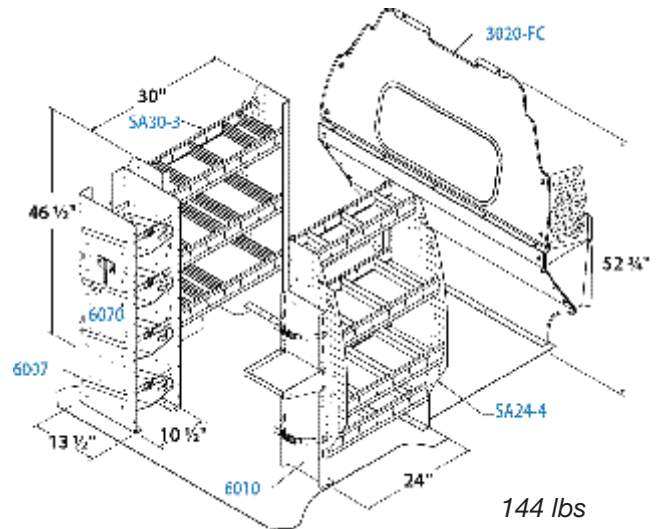

## C212 Deluxe HVAC Package

**RANGER**  
PROLINE

- 1 **3020-FC** Window Partition

---

- 1 **SA24-4** 24" shelf unit with 4 shelves

---

- 1 **SA30-3** 30" shelf unit with 3 shelves

---

- 1 **5010** Partslider

---

- 1 **5025** Jumbo Tool Drawer

---

- 1 **5048** Edge For Partslider

---

- 1 **5070** Partskeeper

---

- 1 **6007** 4 Tier Freon Rack for small bottles

---

- 1 **6010** Two Level Bottle Holder

---

- 1 **6070** Fixed Hook

---

- 1 **7729** Locking Door

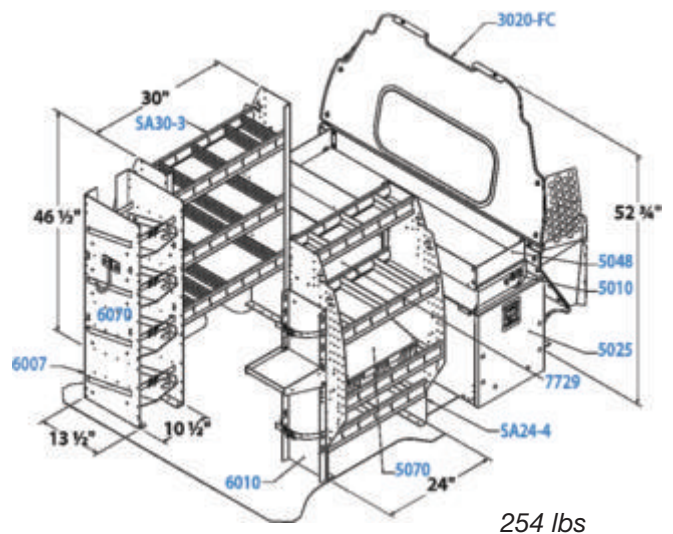

# ALUMINUM CONTRACTOR Package



## Optional

5025, 5010 x 2 & 5048 Drawer stack



## Optional

1525-FC Combination ladder rack  
400 lbs capacity

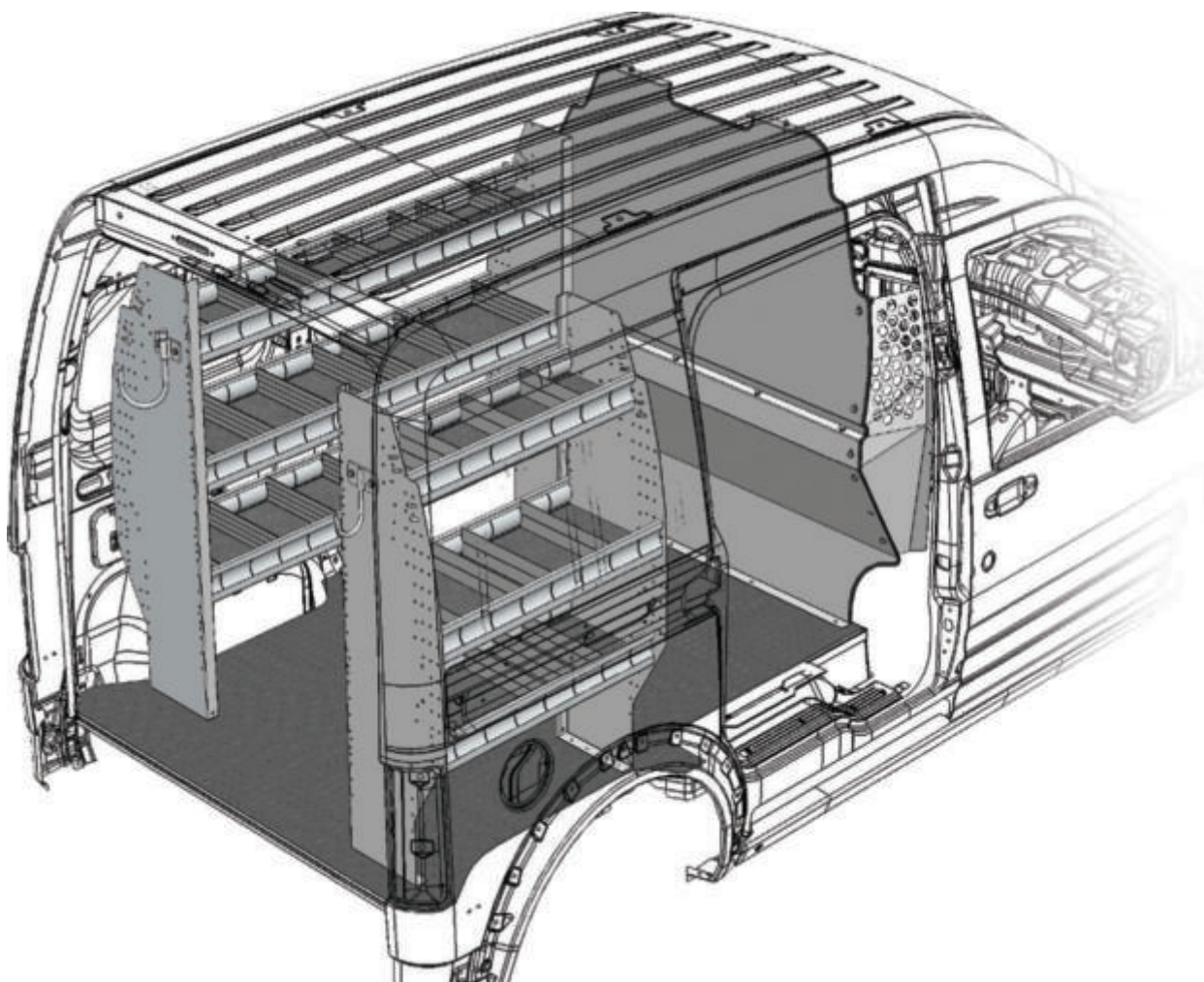
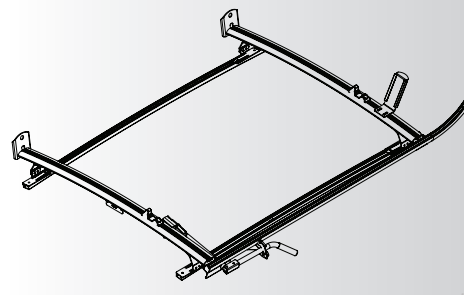

## C310 Base Contractors Package

**RANGER**  
PROLINE

- 1 **3010-FC** Window Partition

---

- 2 **SA30-3** 24" shelf unit with 3 shelves

---

- 1 **6070** 6 Drawer Cabinet

---

- 1 **6072** Swivel Hook

---

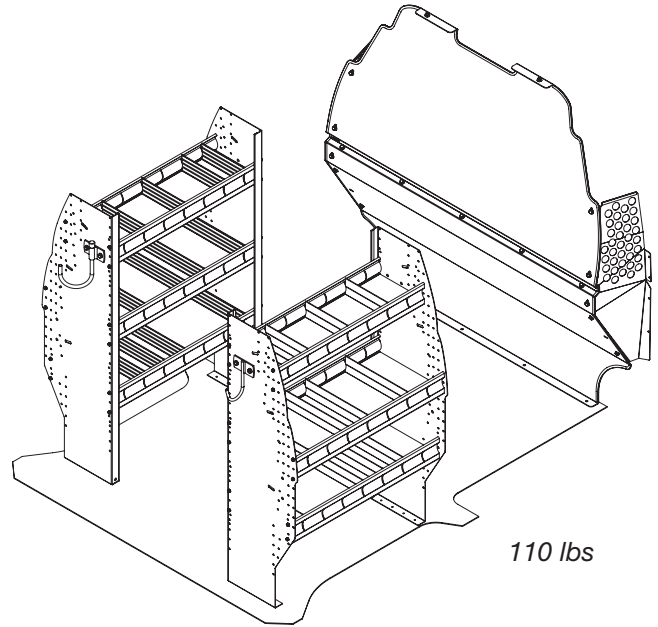
## C210 Deluxe Contractors Package

**RANGER**  
PROLINE

- 1 **3010-FC** Safety Partition

---

- 1 **SA30-3** 30" Shelving unit with 3 shelves

---

- 1 **SA54-3** 54" shelving unit with 3 shelves

---

- 1 **6070** Fixed Hook

---

- 1 **6072** Swivel Hook

---

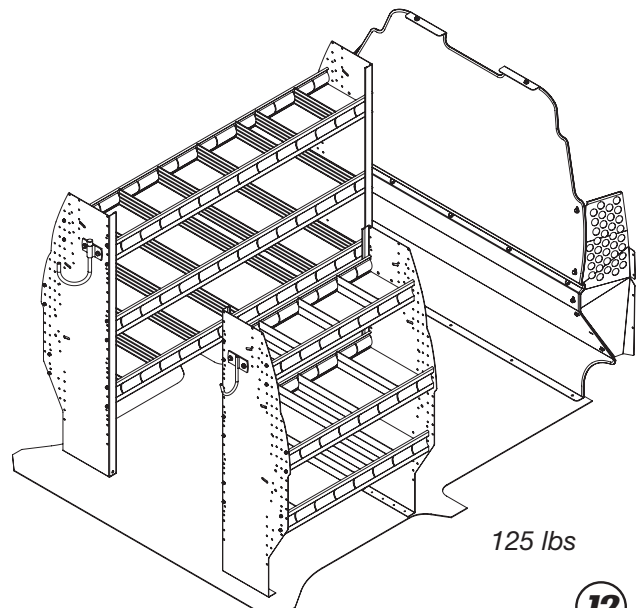
# ALUMINUM DELIVERY Package

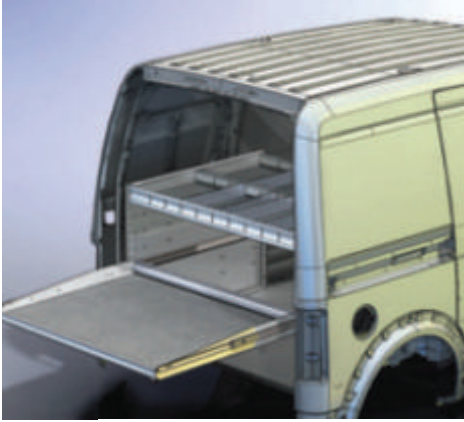

**Optional**  
6067 Paper Holder

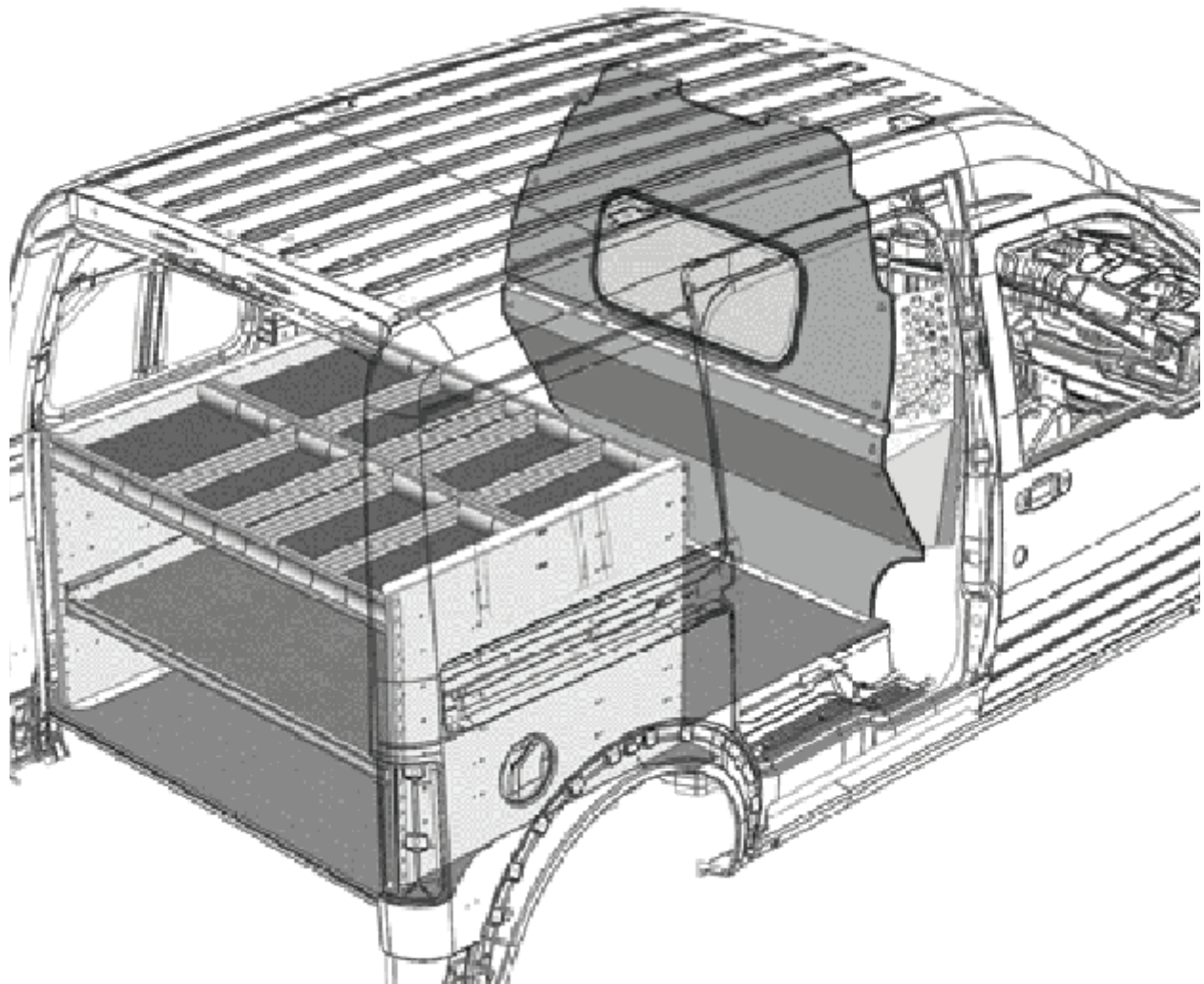
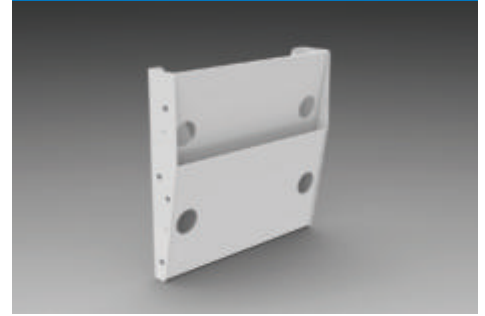

## C319 Base Delivery Package

**RANGER**  
PROLINE

- 1 **3020-FC** Window Partition

---

- 1 **5032-1** Drawer Unit with one sliding shelf

---

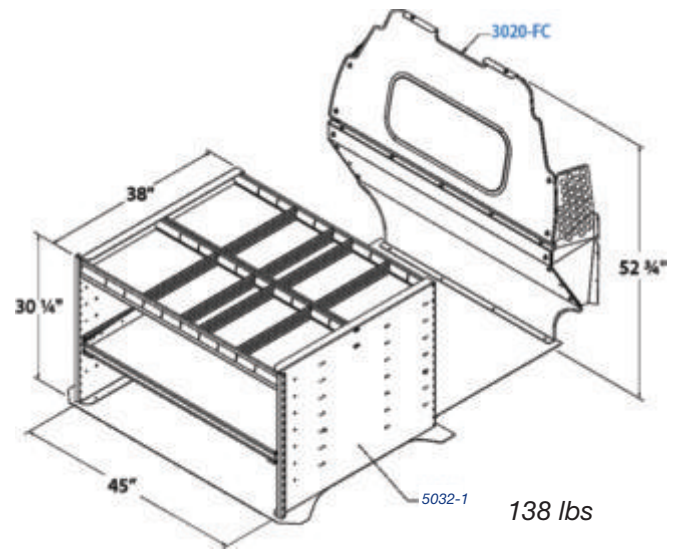
## C219 Deluxe Delivery Package

**RANGER**  
PROLINE

- 1 **3020-FC** Window Partition

---

- 2 **8330-2** 2 Shelf Fold-Away Shelving Unit

---