

Equipment for Commercial Vehicles



**SAVANA / EXPRESS
PACKAGE CATALOG**



ACCELERATE YOUR
BUSINESS WITH
**RANGER
QUICKSHIP**

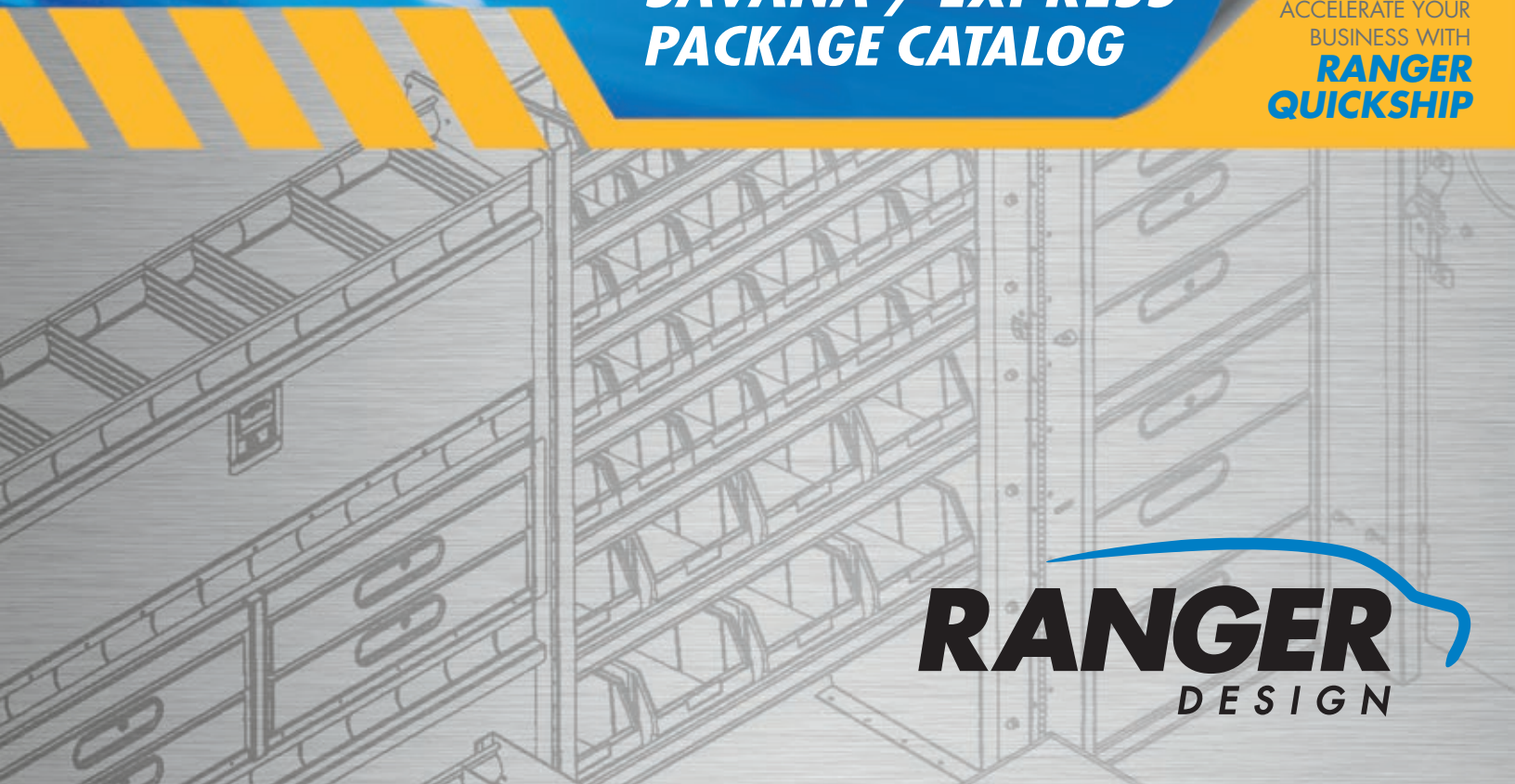

RANGER
DESIGN

215 lbs

Contractor P 3/4
Package

188 lbs

Plumber P 5/6
Package

200 lbs

Service P 7/8
Package



In 1988 a small family business with a passion for innovation and speed of service began to build equipment for commercial vehicles. Now with factories in Rochester, NY and Montreal Canada, and a strong network of dealers across North America, the same passion still drives the company today.

In our modern fast-paced world, Ranger combines old-fashioned service with state of the art technology to bring you consistent quality and strength to meet the toughest demands. This is why more Tradesmen and Fleets across the nation are turning to Ranger solutions for shelving units, storage systems, partitions and ladder racks to answer their unique needs. Contact us today and experience the Ranger difference yourself!

- The Ranger Team



Shelving



Ladder Racks



Fold-Away Shelving

215 lbs



Electrical P 9/10
Package

197 lbs





HVAC P 11/12
Package

152 lbs



Delivery P 13/14
Package

RANGER DESIGN PROVIDES THE POWER OF 24-HOUR SHIPPING

to get you on the road to success faster than ever! Ranger **QUICKSHIP**  guarantees that selected packages with the **QUICKSHIP**  logo will ship within 24 hours if ordered before 1PM. Visit our website www.rangerquickship.com for ordering details or contact one of our Customer Service representatives at cs@rangerdesigninc.com.



Quiet
A peaceful ride
with no rattles



Quick
Fastest lead times
in the industry



Tough
For the toughest



Payload
Engineered to
save weight



Bin Shelving



Drawer Systems



Partitions

STEEL
CONTRACTOR Package



**TOUGH
JOBS
TOUGH
TOOLS**

Optional
W40-A Fleetline cab box

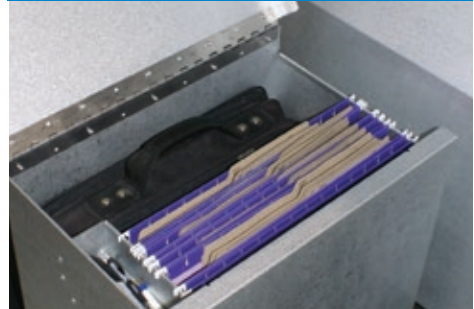

Z05-H Base Contractor Package

RANGER
FLEETLINE

- 1 **C10-H** Contoured partition
- 1 **F87-A** Contoured shelving unit, 87"w
- 1 **F42-A** Contoured shelving unit, 42"w
- 2 **Y30-C** Coat hook



THIS PACKAGE IS
QUICKSHIP

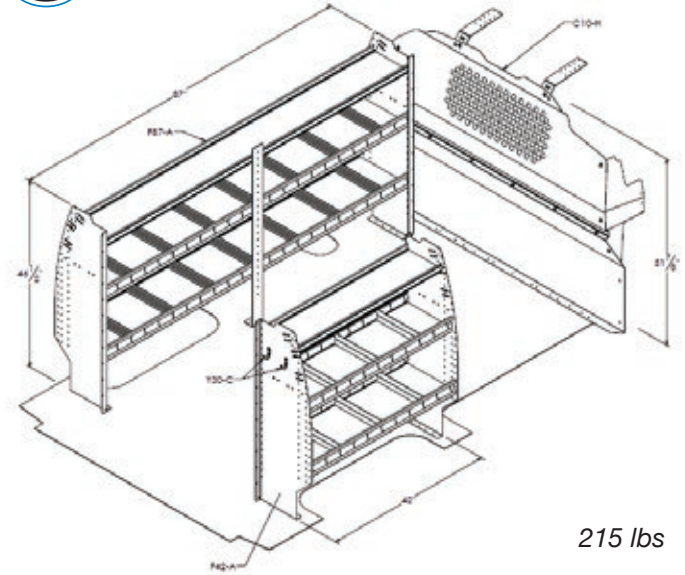

215 lbs

Z30-H Contractor Upgrade Kit

RANGER
FLEETLINE

- 2 **Y11-F** Fleetline locking door
- 1 **6070** Fixed hook
- 1 **Y31-A** 3 Slot paper holder
- 21 **Y35-B** Medium bin



THIS PACKAGE IS
QUICKSHIP

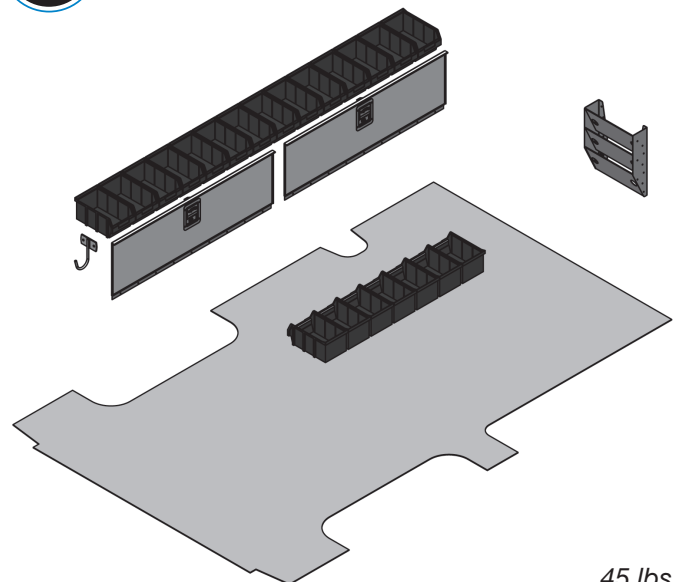

45 lbs

4

ALUMINUM PLUMBER Package



Model # 5078 x 2



Model # 9648



A115 Base Plumber Package

RANGER
PROLINE

- 1 **3010-GS** Contoured safety partition, aluminum

- 1 **4096-3** Contoured shelf unit, aluminum

- 1 **6070** Hook, aluminum, 3" opening

- 1 **6072** Swivel hook, aluminum, 4" opening

- 1 **9648** Deep contoured bin unit, aluminum



THIS PACKAGE IS
QUICKSHIP

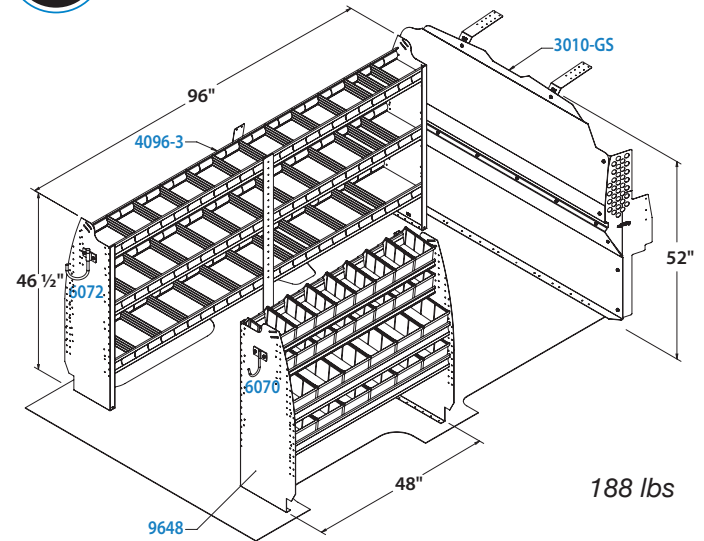

A015 Deluxe Plumber Package

RANGER
PROLINE

- 1 **3010-GS** Contoured safety partition, aluminum

- 1 **4096-3** Contoured shelf unit, aluminum

- 2 **5078** Partskeeper cabinet with 4 carry cases

- 1 **6070** Hook, aluminum, 3" opening

- 1 **6072** Swivel hook, aluminum, 4" opening

- 1 **9648** Deep contoured bin unit, aluminum



THIS PACKAGE IS
QUICKSHIP

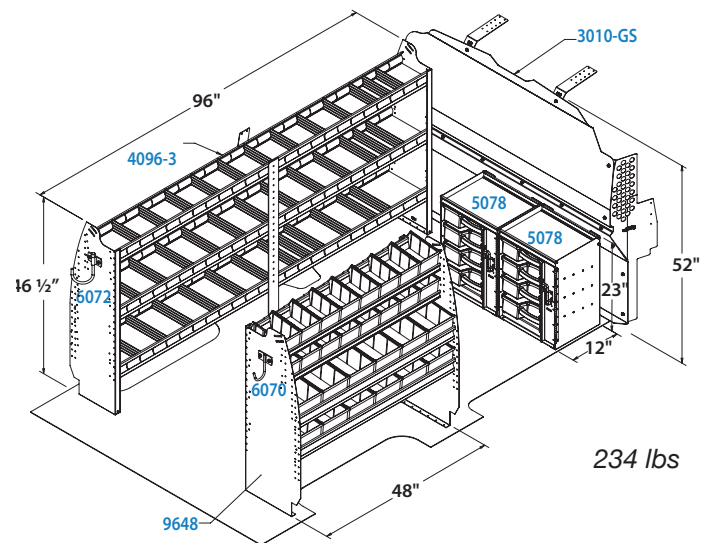

ALUMINUM **SERVICE** Package



Model # 7248



Model # 7109

Optional

1505-FS Cargo rack, 480 lbs capacity



A116 Base Service Package

RANGER
PROLINE

- 1 **3071-FS** Swing door partition, aluminum

- 1 **4096-3** Contoured shelf unit, aluminum

- 1 **6072** Swivel hook, aluminum, 4" opening

- 1 **7248** Workbench, aluminum w/ hardwood top

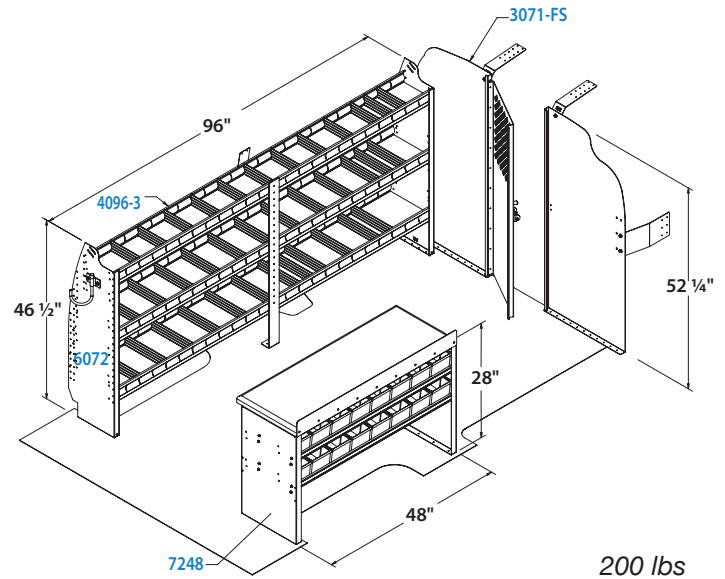

A016 Deluxe Service Package

RANGER
PROLINE

- 1 **3071-FS** Swing door partition, aluminum

- 1 **4096-3** Contoured shelf unit, aluminum

- 1 **6072** Swivel hook, aluminum, 4" opening

- 2 **5070** Partskeeper carry case w/holder

- 1 **7248** Workbench, aluminum w/ hardwood top

- 1 **7109** Bookshelf with three shelves, aluminum

- 1 **7720** Locking door, aluminum, s.s. handle

- 1 **7741** Shelf block

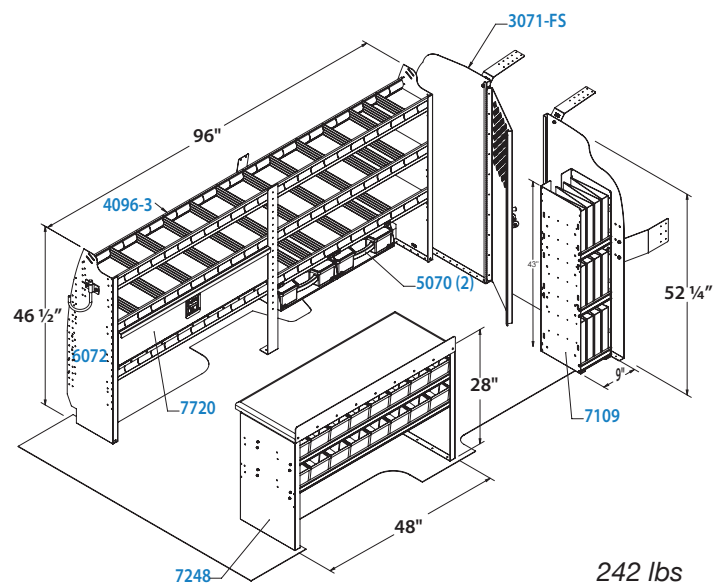

ALUMINUM ELECTRICAL Package

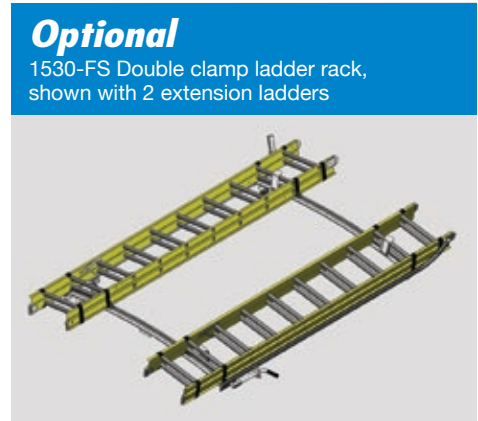

A111 Base Electrical Package

RANGER
PROLINE

- 1 **3010-GS** Contoured safety partition, aluminum
- 1 **4096-3** Contoured shelf unit, aluminum
- 2 **5070** Partskeeper carry case w/holder
- 1 **5248** Contoured bin unit, aluminum
- 1 **6070** Hook, aluminum, 3" opening
- 1 **6072** Swivel hook, aluminum, 4" opening
- 1 **7124** Reel holder with two 5/8" dia. rods
- 1 **7720** Locking door, aluminum, s.s. handle
- 1 **7741** Shelf block

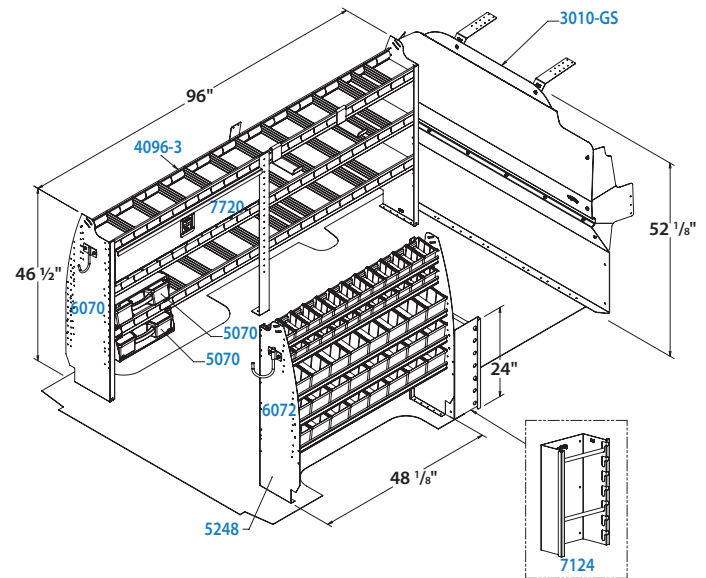

215 lbs

A011 Deluxe Electrical Package

RANGER
PROLINE

- 1 **3010-GS** Contoured safety partition, aluminum
- 1 **4096-3** Contoured shelf unit, aluminum
- 1 **5010** Partslider, aluminum, 150 lbs cap.
- 1 **5020** Tool drawer, aluminum, 320 lbs cap.
- 1 **5048** Top edge, aluminum
- 2 **5070** Partskeeper carry case w/holder
- 1 **5248** Contoured bin unit, aluminum
- 1 **6070** Hook, aluminum, 3" opening
- 1 **6072** Swivel hook, aluminum, 4" opening
- 2 **6073** Large aluminum movable hook
- 1 **7124** Reel holder with two 5/8" dia. rods
- 1 **7720** Locking door, aluminum, s.s. handle
- 1 **7741** Shelf block

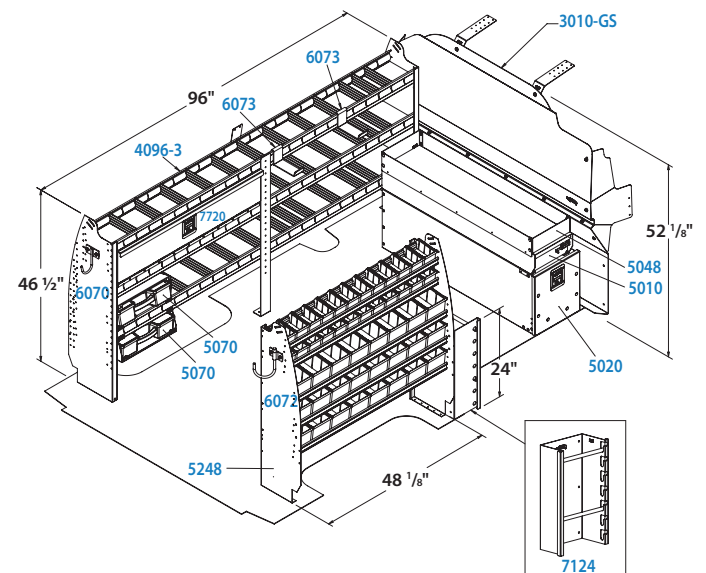

298 lbs

ALUMINUM HVAC Package



Model # 5448



Model # 5025, 5010 (x2), 5048

Optional
1525-FS Combination ladder rack



A112 Base HVAC Package



- 1 **3020-GS** Contoured window partition, aluminum
- 1 **4096-3** Contoured shelf unit, aluminum
- 2 **5070** Partskeeper carry case w/holder
- 1 **5448** Contoured refrigerant bin unit
- 1 **6070** Hook, aluminum, 3" opening
- 1 **6072** Swivel hook, aluminum, 4" opening
- 1 **6086** Small aluminum bottle holder
- 1 **6088** Large aluminum bottle holder
- 1 **7720** Locking door, aluminum, s.s. handle
- 1 **7741** Shelf block

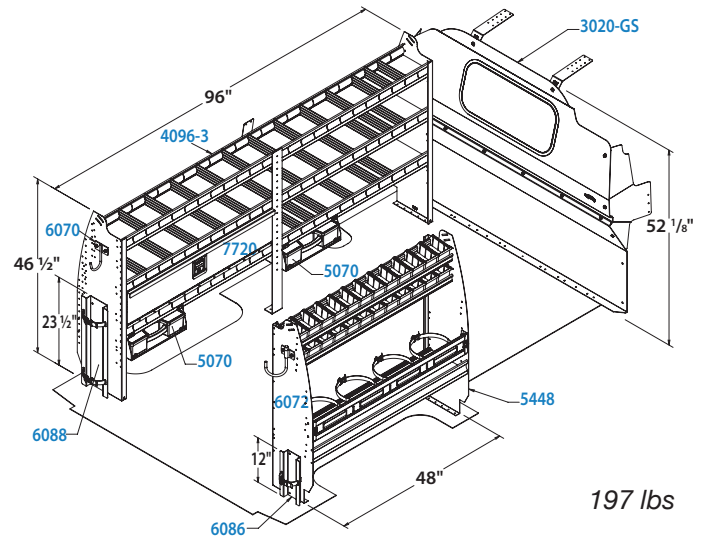

A012 Deluxe HVAC Package



- 1 **3020-GS** Contoured window partition, aluminum
- 1 **4096-3** Contoured shelf unit, aluminum
- 2 **5010** Partslider, aluminum, 150 lbs cap.
- 1 **5025** Jumbo tool drawer, aluminum, 320 lbs cap.
- 1 **5048** Top edge, aluminum
- 2 **5070** Partskeeper carry case w/holder
- 1 **5448** Contoured refrigerant bin unit
- 1 **6070** Hook, aluminum, 3" opening
- 1 **6072** Swivel hook, aluminum, 4" opening
- 1 **6086** Small aluminum bottle holder
- 1 **6088** Large aluminum bottle holder
- 1 **7720** Locking door, aluminum, s.s. handle
- 1 **7741** Shelf block

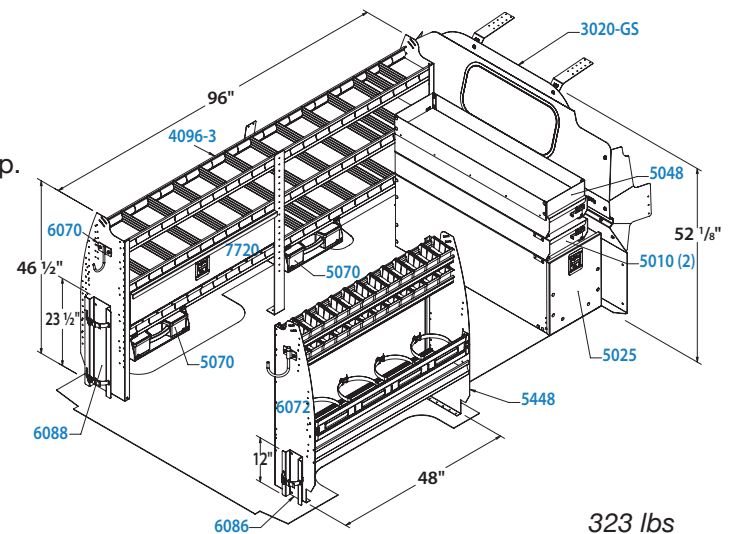

ALUMINUM DELIVERY Package



Optional
6067 Paper Holder



A119 Regular Length Delivery Package

RANGER
PROLINE

1 **3064-FS** Set of single partitions, aluminum

1 **8572-2** Fold-Away shelving unit, 2 levels, aluminum

1 **8548-2** Fold-Away shelving unit, 2 levels, aluminum

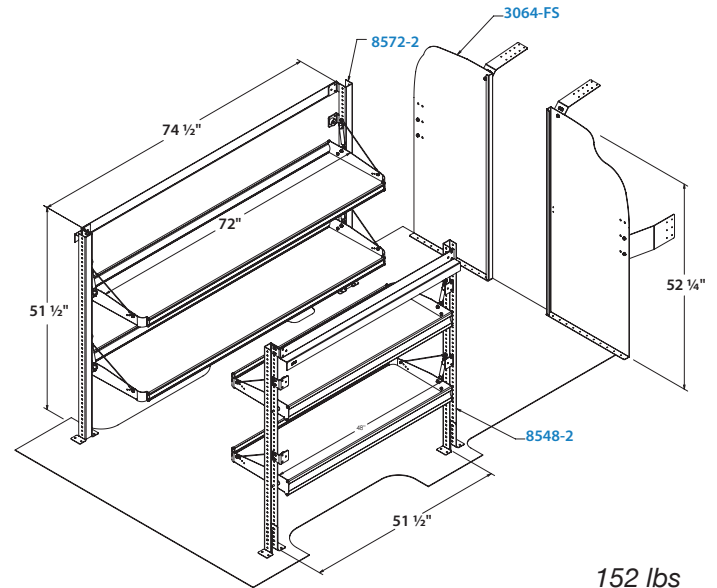

152 lbs

A019 Extended Length Delivery Package

RANGER
PROLINE

1 **3064-FS** Set of single partitions, aluminum

2 **8548-2** Fold-Away shelving unit, 2 levels, aluminum

1 **84-7051** Fold-Away aluminum post with steel foot

2 **84-1848** Fold-Away shelf tray with gas shocks and hardware

1 **84-3051** Mounting bar

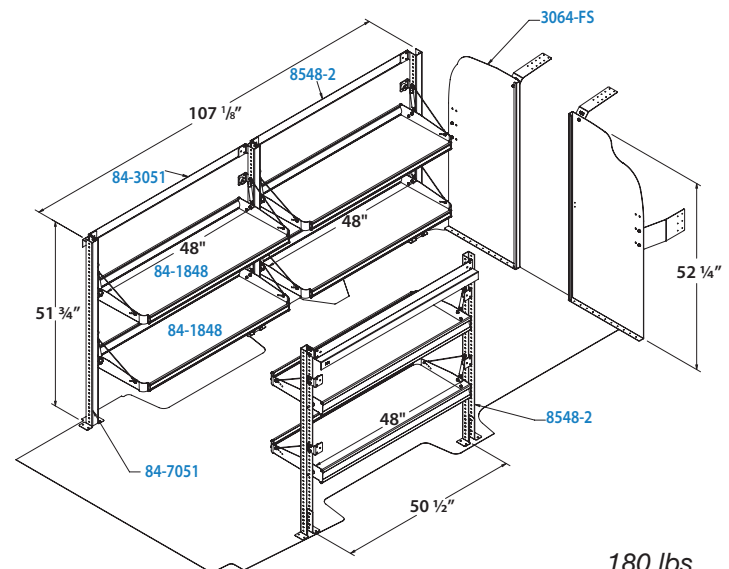

180 lbs

Savana / Express Layout Guide

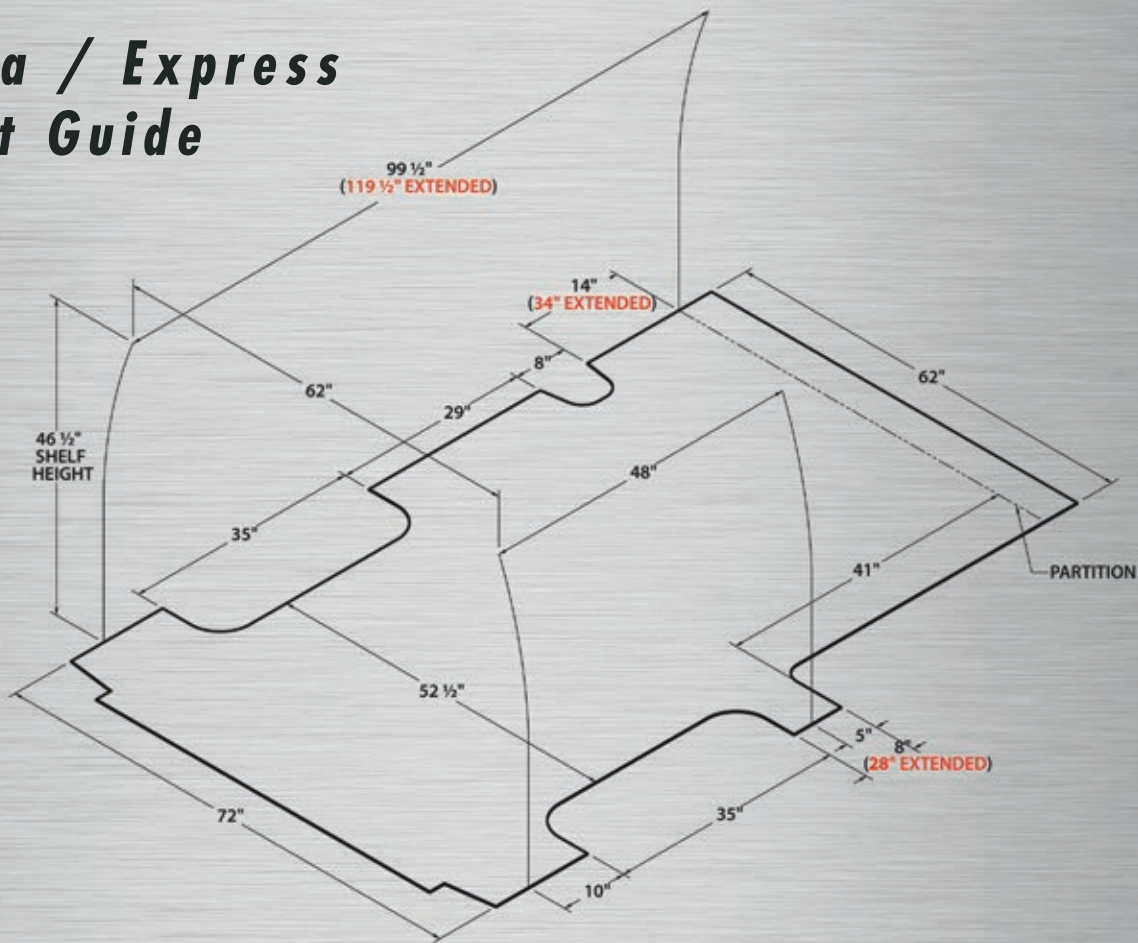

RANGER
DESIGN

Customer Service:
(800)565-5321
cs@rangerdesigninc.com

www.rangerdesign.com
info@rangerdesign.com



Your Local Dealer:

M110-122