



EQUIPMENT
FOR CARGO VANS



// RANGER UPFIT GUIDE

PROMASTER

WORK MORE EFFECTIVELY WITH ORGANIZED STORAGE SOLUTIONS

Welcome to Ranger Design

In 1988 a local contractor made his own shelving for his work van. His peers saw the superior design and durability of his equipment and they wanted him to make the same for their vehicles.

Over 25 years later Ranger Design still looks at van equipment from the tradesman's point of view.

Every product in this catalog is designed with precision. Our tough, durable products often outlast the life of the vehicle and we go to pains to make each component quiet and rattle free.

In our everyday pursuit of excellence we confer with tradesmen often to ensure that we are delivering bottom line results.

We look forward to hearing from you on how we can make our products and services serve you better.
1-800-565-5321.



Rochester, NY
Manufacturing Plant



San Francisco, CA
Sales Office



Montreal, Canada
Manufacturing Plant



TABLE OF CONTENTS

LAYOUT GUIDES

P. 6

PARTITIONS

P. 8

FLOORS

P. 10

PACKAGES

P. 12

SHELVING & INSTALL KITS

P. 34

DRAWERS & ACCESSORIES

P. 42

LADDER RACKS

P. 48

HOW TO ORDER

P. 52

FLEET

P. 53

INDEX

P. 54



CHOOSE



RANGER
FLEETLINE

RANGER
PROLINE

RANGER PRODUCT LINE OPTIONS

Throughout the catalog **FLEETLINE** products are depicted with yellow and **PROLINE** products with blue.

FLEETLINE
STEEL

PROLINE
ALUMINUM

SELECTING FLEETLINE OR PROLINE

Ranger Fleetline and Proline product groups ensure that fleets of any size have the best equipment to fit their budget, trade or fuel saving targets.

	MATERIAL	BENEFITS	PRODUCTS	WARRANTY
<p>WHY BUY RANGER FLEETLINE?</p> <p>You want better quality and price than other steel products on the market.</p>	Steel	Tough Low cost Quiet	Shelving, Partitions, Drawers, Accessories	3 years
<p>WHY BUY RANGER PROLINE?</p> <p>You want the toughest, quietest product on the market. You need to optimize payload without sacrificing quality.</p>	Aluminum	Toughest Lightweight Quiet	Shelving, Partitions, Drawers, Accessories, Ladder Racks	10 years

Ranger Design Inc. van equipment is warranted to be free from defects in material and workmanship under normal use and service for the period indicated, from the date of the original retail purchase, when installed per Ranger Design instructions.



WORLD CLASS CUSTOMER SERVICE

1-800-565-5321
7 A.M. – 8 P.M. EST

REAL PEOPLE, READY TO ANSWER IN 2 RINGS OR LESS*

We are pleased to offer efficient, personalized service and to answer all questions regarding:

- › Pricing/Quoting
- › Consultation
- › Product specifications
- › Returns/Restocking
- › Product install
- › Shipment status
- › Warranty claims
- › Vehicle specifications
- › Order status
- › New product availability

*Call customer service and the phone will be answered in 2 rings or less. Yes, a real, live person working in one of our offices in North America is available to answer your questions. No automated attendant. No complicated phone tree and offshore service. Call us to experience the difference.



LAYOUT GUIDES

CHOOSE THE RIGHT SIZE VAN FOR YOUR NEEDS

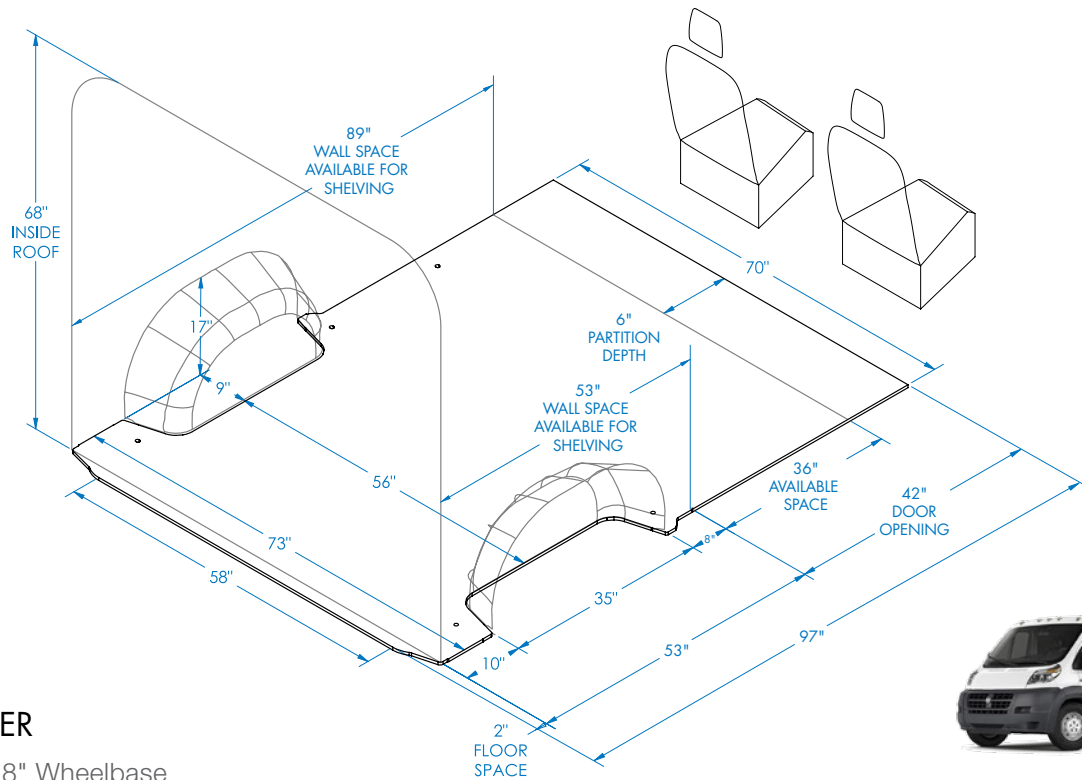

RAM PROMASTER

Standard 118" Wheelbase

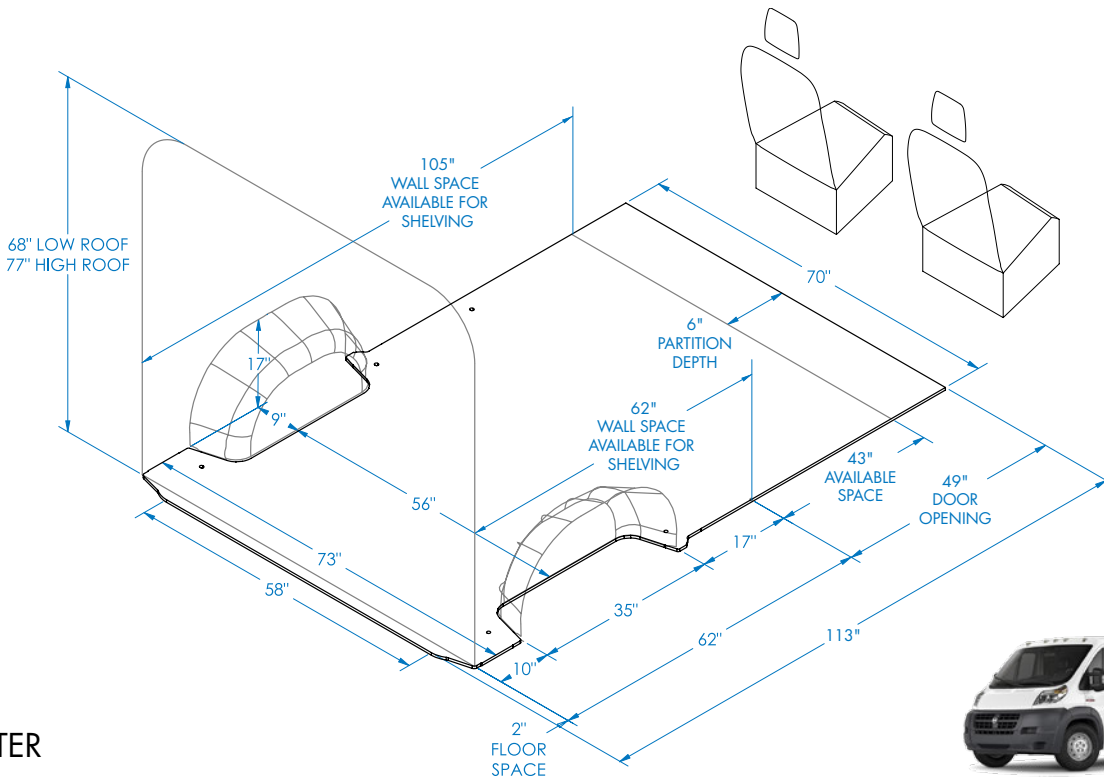

RAM PROMASTER

Medium 136" Wheelbase

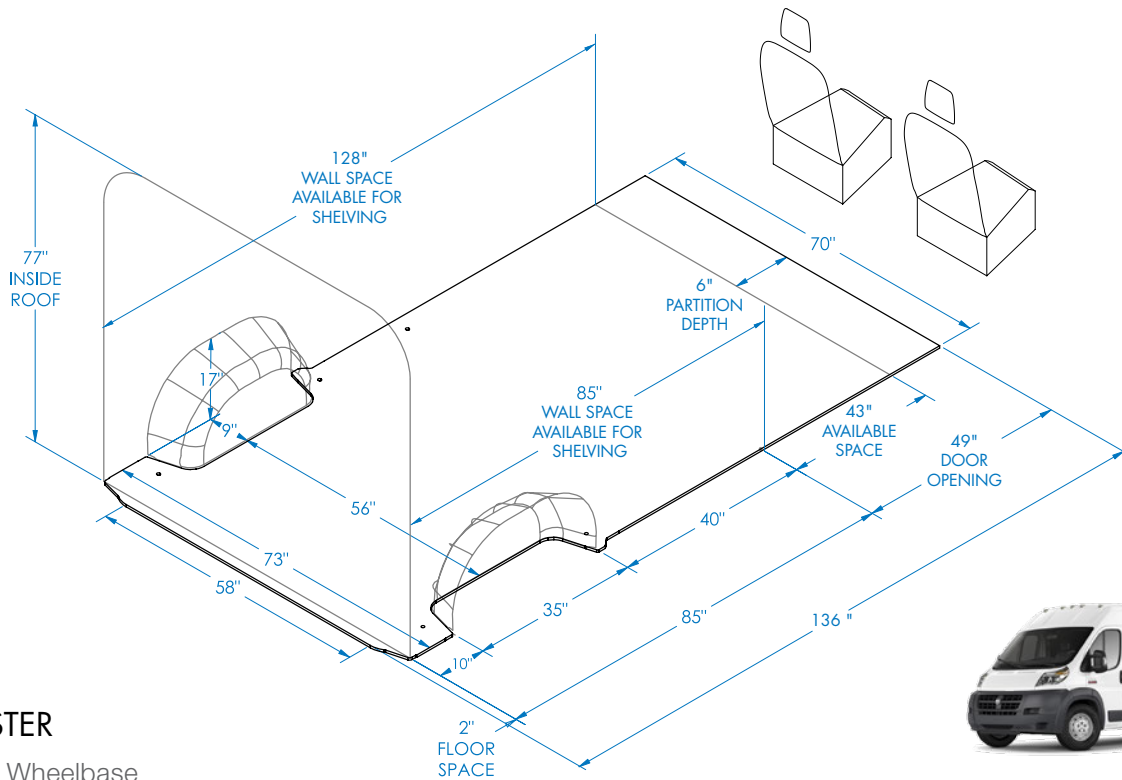

RAM
PROMASTER
 Long 159" Wheelbase

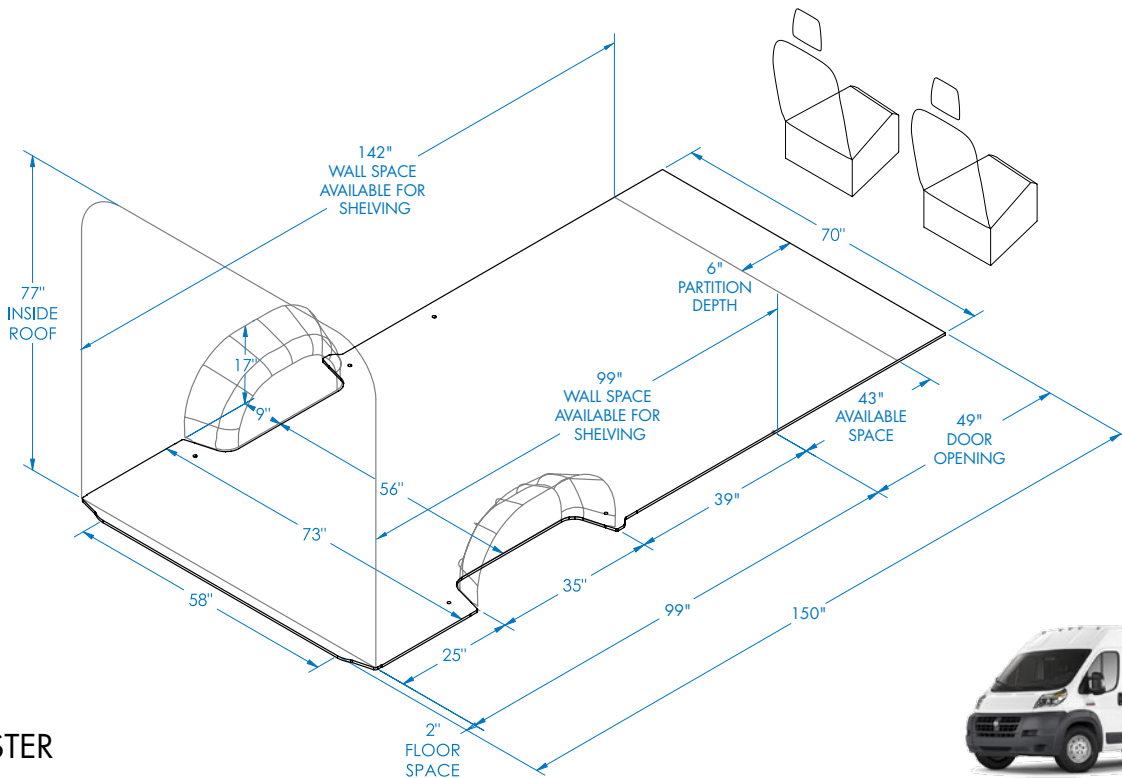

RAM
PROMASTER
 Extended 159" Wheelbase



SAFETY PARTITIONS

Crash tested safety partitions protect the most important asset: you



CHOOSE A SAFETY PARTITION

Ranger safety partitions provide a solid, secure barrier between the occupants of the van and the cargo.

Built from heavy gauge steel and aluminum, they are designed for maximum impact resistance, and uphold a standard of safety set only by Ranger products.



Ranger partitions also provide a more comfortable environment for the driver by giving more seat travel and by not rattling as the vehicle drives down the road.



3020-RP

Contoured Safety Partition with Tempered Glass Window

Aluminum

	63 lbs
	1 hr
	Yes

BENEFITS



- › Best possible visibility
- › Crash tested
- › Contoured for maximum seat travel and driver comfort



3068-RP

Straight Partition with Tempered Glass Window, Sliding Door

Aluminum

	59 lbs
	1.5 hrs
	Yes

BENEFITS

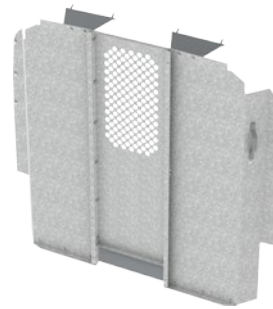

- › Fast easy access
- › Good visibility
- › Keyed lock
- › Sliding door won't get blocked by cargo on the floor



C20-X

Straight Partition with Perforated Window, No Access

Steel

	78 lbs
	1 hr
	Yes

BENEFITS



- › Low cost
- › Good protection
- › Secures cargo area



C30-X

Straight Partition with Perforated Window, Swing Door

Steel

	80 lbs
	1 hr
	Yes

BENEFITS

- › Access to cargo area
- › Low cost
- › Solid steel protection

FLOORS

Impact and puncture resistant floors preserve the cargo van interior



BENEFIT

Installing a Ranger floor will greatly reduce road noise.

CHOOSE YOUR FLOOR PROTECTION

Protect the inside of your vehicle with a slip-resistant floor. Ultragrip floors provide a safe surface for technicians as well as reducing the chance of shifting loads. Each floor is vehicle specific and designed for perfect fit.

These durable floors are easy to install and simple to clean. Puzzle-joint to economize on shipping.

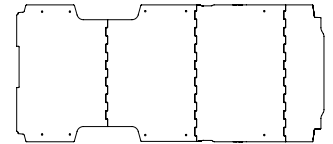
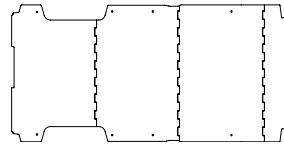
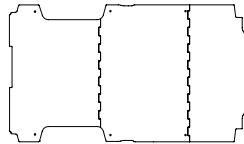
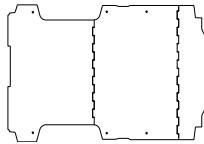

6520

HD Ultra Grip Floor
Composite

	118" Standard
	94 lbs
	0.33 hr

6521

HD Ultra Grip Floor
Composite

	136" Medium
	112 lbs
	0.33 hr

6522

HD Ultra Grip Floor
Composite

	159" Long
	135 lbs
	0.33 hr

6523

HD Ultra Grip Floor
Composite

	159" Extended
	150 lbs
	0.33 hr



PROTECTION

Rigid floor covering protects cargo van floors from impact damage and scratches.



SAFETY

Ultragrip floor also minimizes the chances of slipping and reduces shifting of cargo.



EFFICIENCY

Ultragrip floors provide technicians with a durable work surface that is easy to clean.



TRADE PACKAGES

Pre-engineered packages
for a broad range of trades



BENEFIT

Ranger maximizes your work van! We make sure that our packages give you the most possible workspace in your vehicle.



CHOICE

A range of steel and aluminum packages are available for each vehicle. (See P. 4)



TRADE SPECIFIC

Packages are created with the specific trades in mind. Optimized for maximum productivity.



PERFECT FIT

Engineered to optimize space. Layout designed to ensure that all tools are well within reach.

CHOOSE A TRADE PACKAGE

Choose a package that suits your needs. If you can't find a package exactly suited to your needs, contact Ranger Customer Service or your local Ranger Distributor to assist you.

PROMASTER CARGO VAN

CONTRACTOR P. 14

SERVICE/LOCKSMITH P. 18

ELECTRICAL P. 22

HVAC/PLUMBING P. 26

DELIVERY P. 28

PROMASTER BOX TRUCK & TRAILERS

CONTRACTOR P. 32

HVAC/PLUMBING P. 32

SERVICE/LOCKSMITH P. 33

DELIVERY P. 33

Get more out of your work van: Ranger packages are designed specifically with your trade in mind. Our aim is to ensure that your most frequently used tools and equipment are well within reach.

Do you see a way that we can improve our packages? We appreciate your feedback! Contact our customer service team at **1-800-565-5321**.





// Z10-E1 CONTRACTOR PACKAGE

// TOUGH

Extrusion builds durability into shelf.

// QUIET

The combination of the extrusion, shelf tray, and end-panels create durable, vibration-free shelves.

// EFFICIENT

Ergonomic design reduces injuries and increases productivity.



*Preproduction model shown,
do not use as an installation guide.

PACKAGES

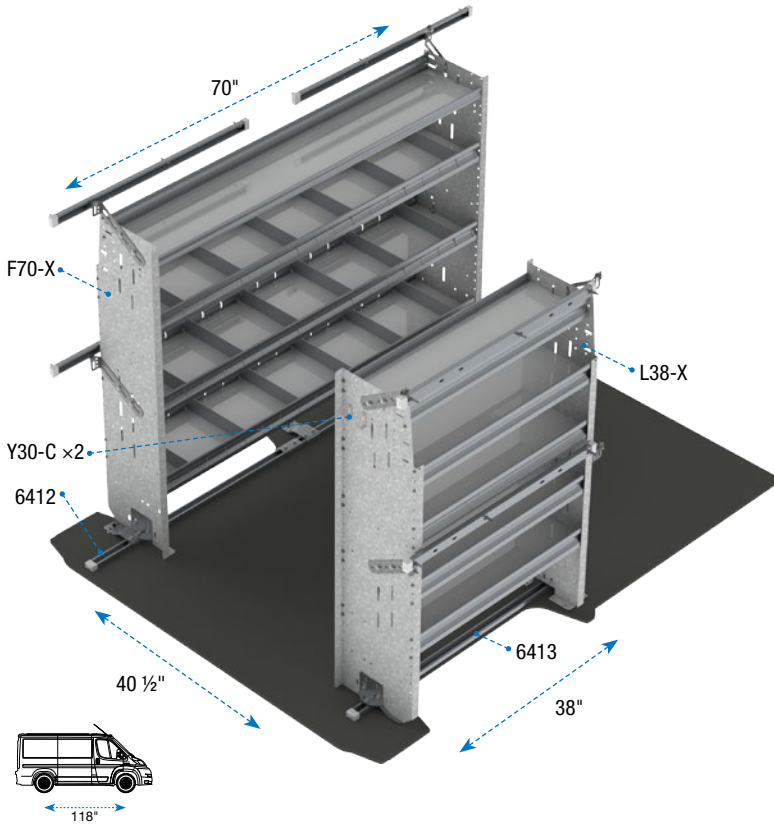

Z10-E0

Base Contractor Package

Steel

Standard

201 lbs

2.4 hrs

Yes

Qty	Part #	Description
1	6412	Shelf unit install kit
1	6413	Shelf unit install kit
1	F70-X	Shelf unit, square back
1	L38-X	Shelf unit, square back
2	Y30-C	Small hook

**ADD AN
X51-F**



P. 45

Z10-E1

Base Contractor Package

Steel

Medium

231 lbs

2.4 hrs

Yes

Qty	Part #	Description
1	6414	Shelf unit install kit
1	6415	Shelf unit install kit
1	F87-X	Shelf unit, square back
1	L42-X	Shelf unit, square back
2	Y30-C	Small hook

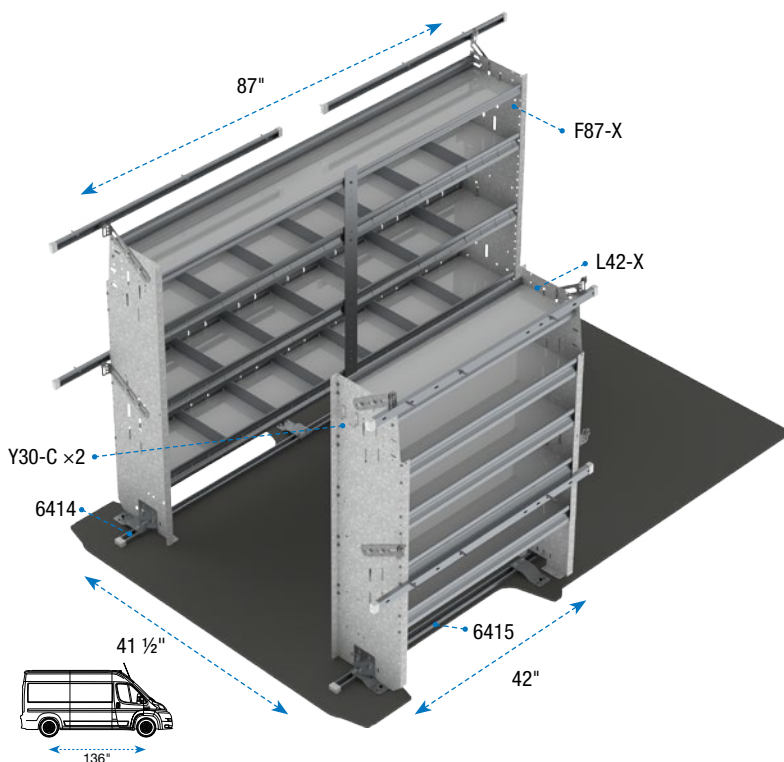

**PICK YOUR
DRAWERS**



P. 42

**CONTRACTOR
CARGO VAN**

STEEL PACKAGES

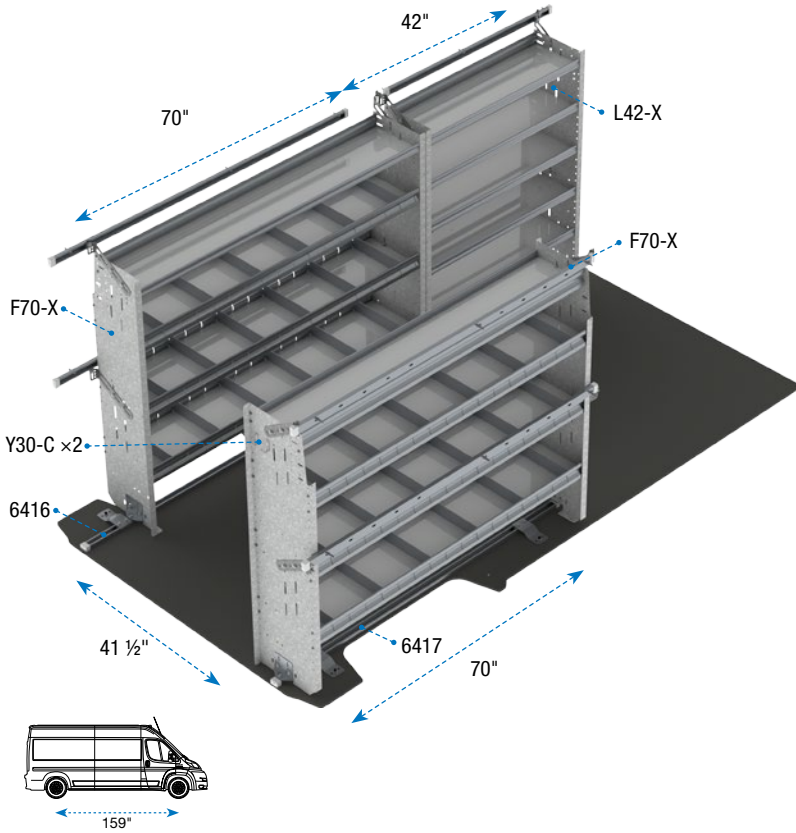

Z10-E2

Base Contractor Package

Steel

Long	316 lbs	3.4 hrs
Yes		

Qty	Part #	Description
1	6416	Shelf unit install kit
1	6417	Shelf unit install kit
2	F70-X	Shelf unit, square back
1	L42-X	Shelf unit, square back
2	Y30-C	Small hook

**PICK YOUR
PARTITION**



P. 8

PACKAGES

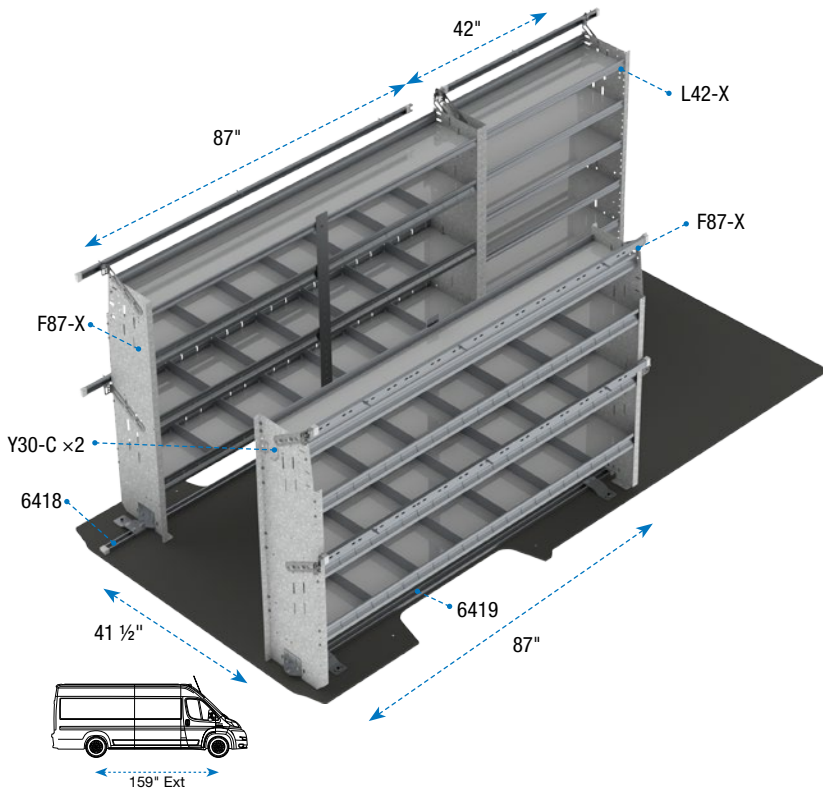

Z10-E3

Base Contractor Package

Steel

Extended	365 lbs	3.4 hrs
Yes		

Qty	Part #	Description
1	6418	Shelf unit install kit
1	6419	Shelf unit install kit
2	F87-X	Shelf unit, square back
1	L42-X	Shelf unit, square back
2	Y30-C	Small hook

**PICK YOUR
ACCESSORIES**



P. 42

LEGEND

- Wheelbase
- Weight of Package
- Install Time
- Quickship



// Z16-E1

SERVICE / LOCKSMITH PACKAGE

// TOUGH

Extrusion builds durability into shelf.

// QUIET

The combination of the extrusion, shelf tray, and end-panels create durable, vibration-free shelves.

// EFFICIENT

Ergonomic design reduces injuries and increases productivity.



*Preproduction model shown, do not use as an installation guide.

STEEL PACKAGES

SERVICE/LOCKSMITH CARGO VAN

PACKAGES

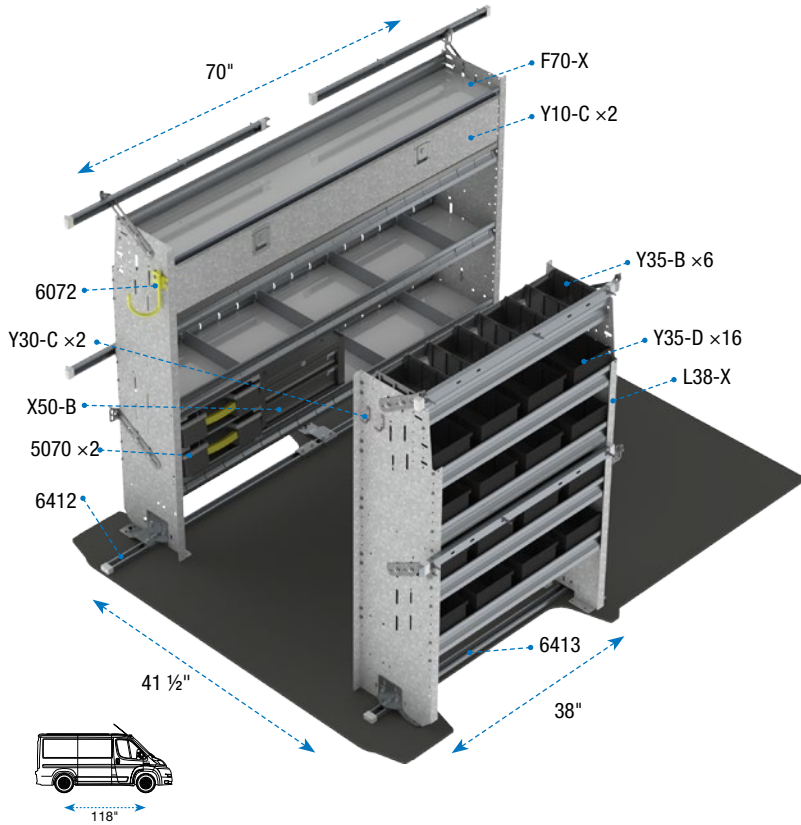

Z16-E0

Service/Locksmith Package

Steel

Standard

278 lbs

4.9 hrs

Yes

Qty	Part #	Description
2	5070	Partskeeper, shelf mount
1	6072	8" swivel hook with 4" opening
1	6412	Shelf unit install kit
1	6413	Shelf unit install kit
1	F70-X	Shelf unit, square back
1	L38-X	Shelf unit, square back
1	X50-B	Drawer cabinet
2	Y10-C	Locking door kit
2	Y30-C	Small hook
6	Y35-B	Stacking bin, medium
16	Y35-D	Stacking bin, large

Z16-E1

Service/Locksmith Package

Steel

Medium

319 lbs

4.9 hrs

Yes

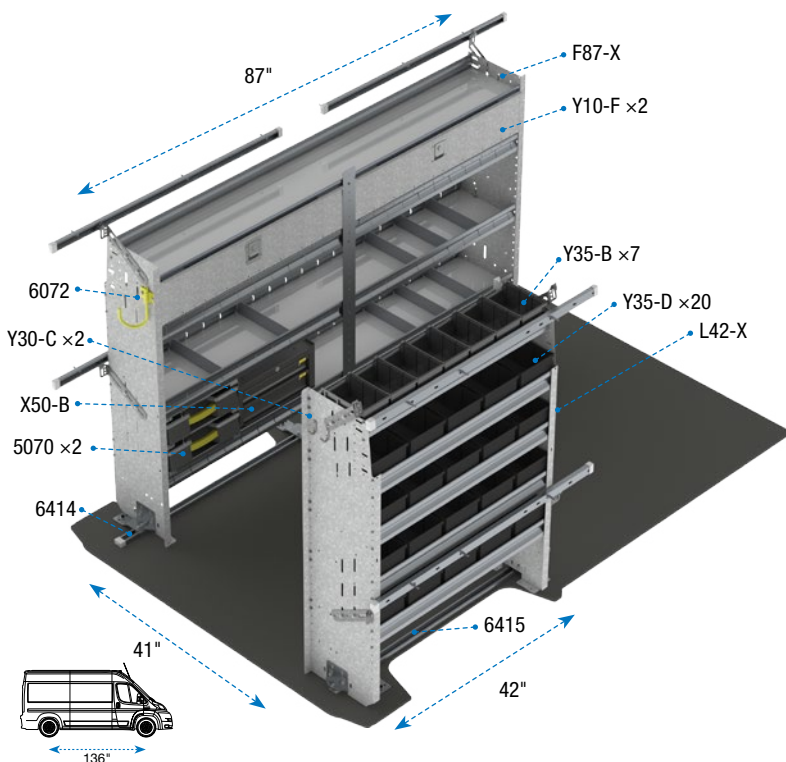

Qty	Part #	Description
2	5070	Partskeeper, shelf mount
1	6072	8" swivel hook with 4" opening
1	6414	Shelf unit install kit
1	6415	Shelf unit install kit
1	F87-X	Shelf unit, square back
1	L42-X	Shelf unit, square back
1	X50-B	Drawer cabinet
2	Y10-F	Locking door kit
2	Y30-C	Small hook
7	Y35-B	Stacking bin, medium
20	Y35-D	Stacking bin, large

SERVICE/LOCKSMITH CARGO VAN

STEEL PACKAGES

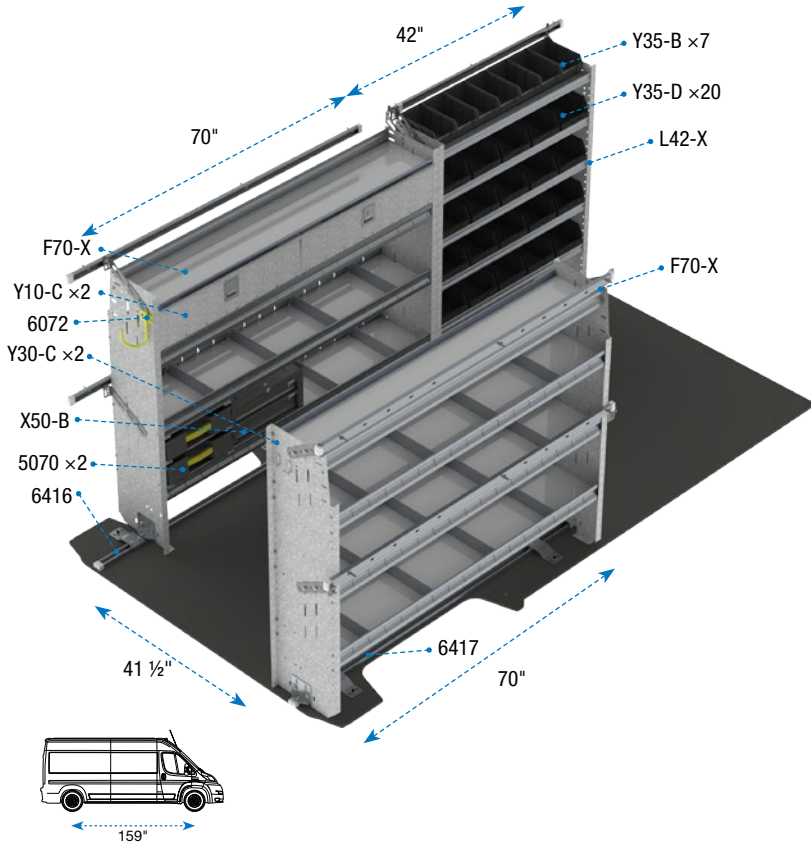

Z16-E2

Service/Locksmith Package

Steel

Long	398 lbs	5.9 hrs
Yes		

Qty	Part #	Description
2	5070	Partskeeper, shelf mount
1	6072	8" swivel hook with 4" opening
1	6416	Shelf unit install kit
1	6417	Shelf unit install kit
2	F70-X	Shelf unit, square back
1	L42-X	Shelf unit, square back
1	X50-B	Drawer cabinet
2	Y10-C	Locking door kit
2	Y30-C	Small hook
7	Y35-B	Stacking bin, medium
20	Y35-D	Stacking bin, large

PACKAGES

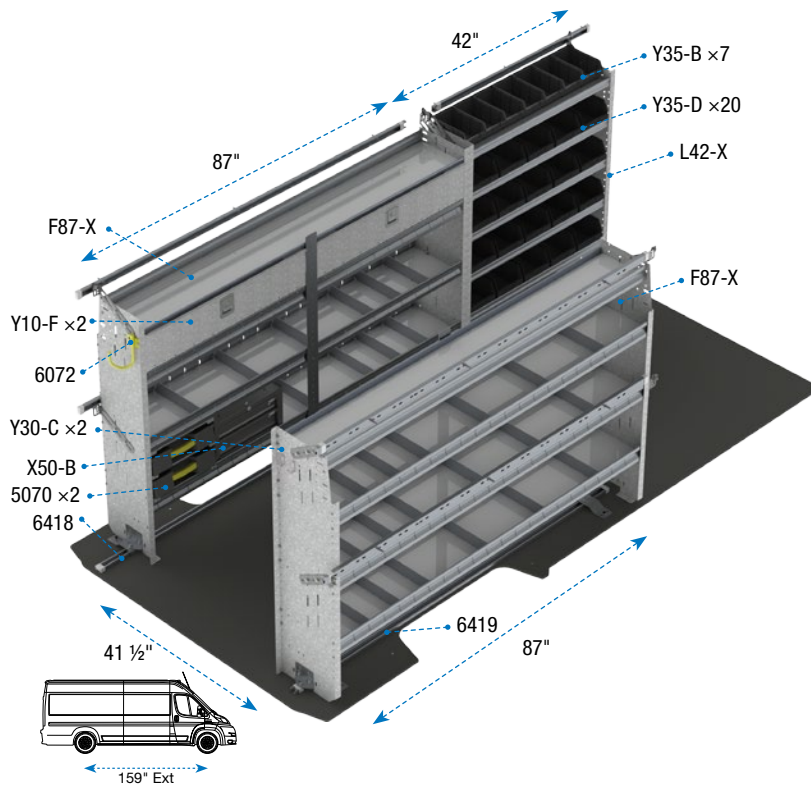

Z16-E3

Service/Locksmith Package

Steel

Extended	453 lbs	5.9 hrs
Yes		

Qty	Part #	Description
2	5070	Partskeeper, shelf mount
1	6072	8" swivel hook with 4" opening
1	6418	Shelf unit install kit
1	6419	Shelf unit install kit
2	F87-X	Shelf unit, square back
1	L42-X	Shelf unit, square back
1	X50-B	Drawer cabinet
2	Y10-F	Locking door kit
2	Y30-C	Small hook
7	Y35-B	Stacking bin, medium
20	Y35-D	Stacking bin, large



// E111 ELECTRICAL PACKAGE

// TOUGH

Extrusion builds durability into shelf.

// QUIET

The combination of the extrusion, shelf tray, and end-panels create durable, vibration-free shelves.

// EFFICIENT

Ergonomic design reduces injuries and increases productivity.



*Preproduction model shown,
do not use as an installation guide.

ALUMINUM PACKAGES

**ELECTRICAL
CARGO VAN**

PACKAGES

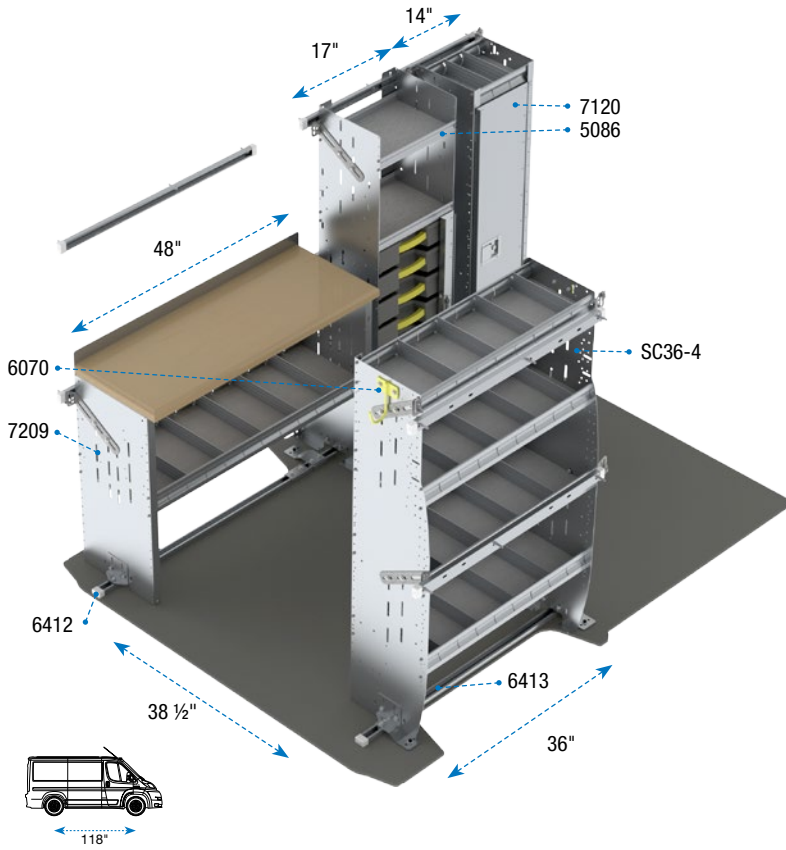

E011

Electrical Package

Aluminum

Standard

225 lbs

4.6 hrs

Yes

Qty	Part #	Description
1	5086	Partskeeper cabinet
2	6070	6" hook with 3" opening
1	6412	Shelf unit install kit
1	6413	Shelf unit install kit
1	7120	Locker, high roof
1	7209	Workbench
1	SC36-4	Shelf unit, 36" L

ADD A COMPACT DRAWER UNIT

P. 42

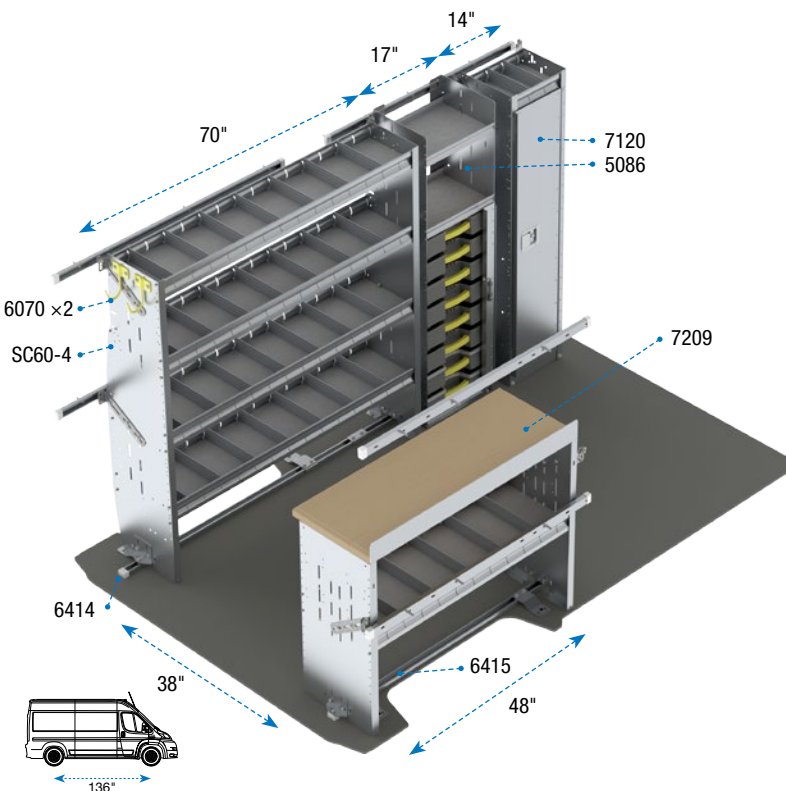

E111

Electrical Package

Aluminum

Medium

248 lbs

4.6 hrs

Yes

Qty	Part #	Description
1	5086	Partskeeper cabinet
2	6070	6" hook with 3" opening
1	6414	Shelf unit install kit
1	6415	Shelf unit install kit
1	7120	Locker, high roof
1	7209	Workbench
1	SC60-4	Shelf unit, 60" L

PICK YOUR DRAWERS

P. 42



ELECTRICAL CARGO VAN

ALUMINUM PACKAGES

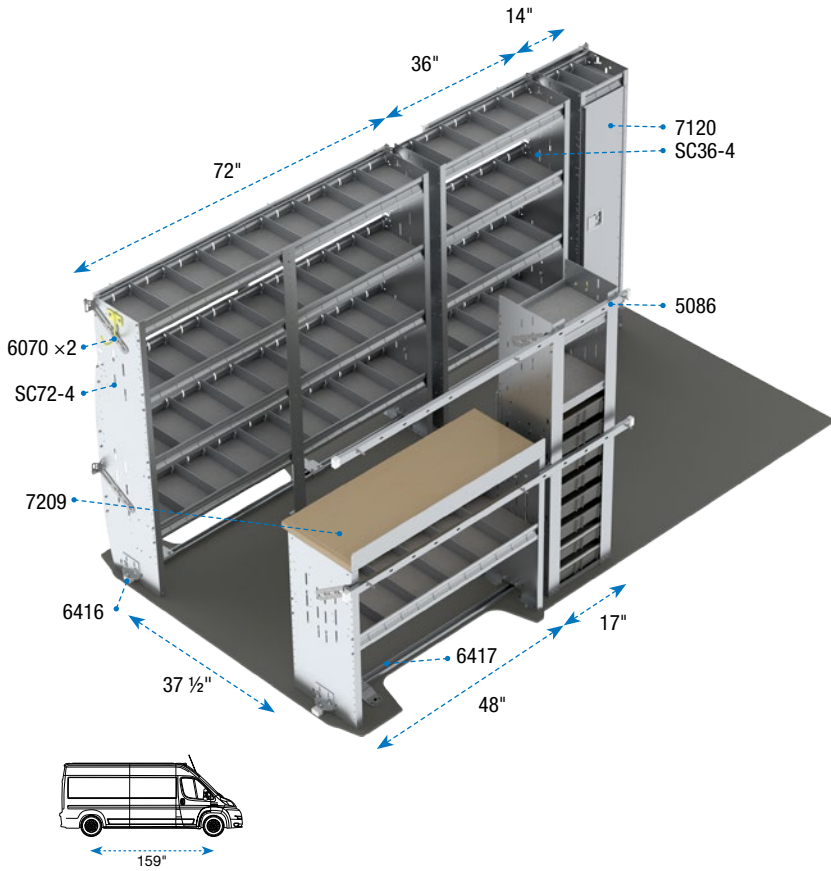

E211

Electrical Package

Aluminum

Long	310 lbs	6 hrs
Yes		

Qty	Part #	Description
1	5086	Partskeeper cabinet
2	6070	6" hook with 3" opening
1	6416	Shelf unit install kit
1	6417	Shelf unit install kit
1	7120	Locker, high roof
1	7209	Workbench
1	SC36-4	Shelf unit, 36" L
1	SC72-4	Shelf unit, 72" L

PICK YOUR PARTITION



P. 8

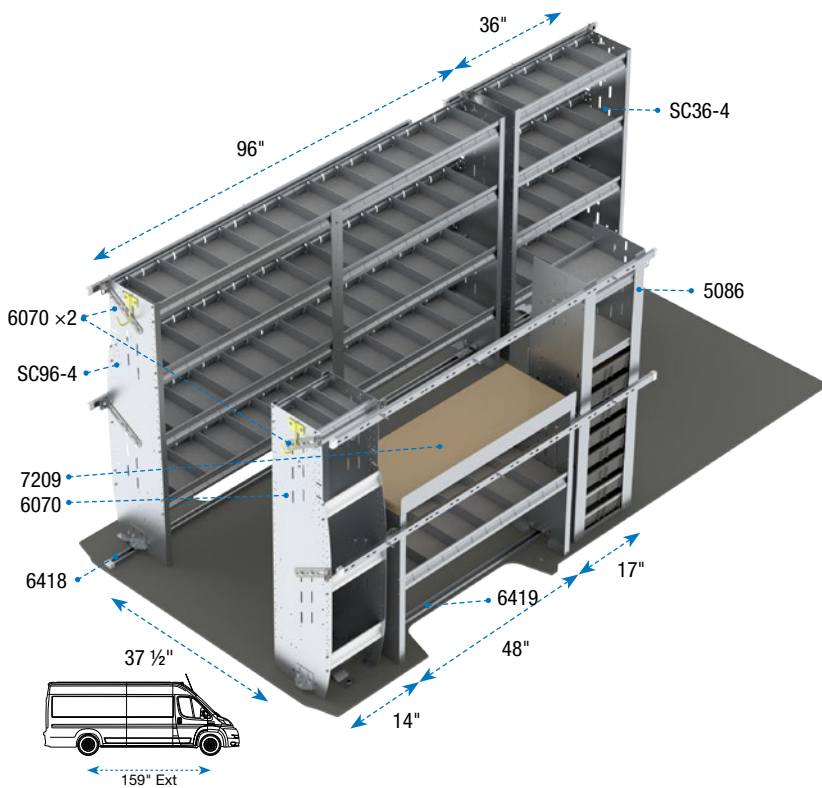

E311

Electrical Package

Aluminum

Extended	335 lbs	6 hrs
Yes		

Qty	Part #	Description
1	5086	Partskeeper cabinet
2	6070	6" hook with 3" opening
1	6418	Shelf unit install kit
1	6419	Shelf unit install kit
1	7120	Locker, high roof
1	7209	Workbench
1	SC36-4	Shelf unit, 36" L
1	SC96-4	Shelf unit, 96" L

PICK YOUR ACCESSORIES



P. 42

ALUMINUM PACKAGES

HVAC/PLUMBING CARGO VAN

PACKAGES

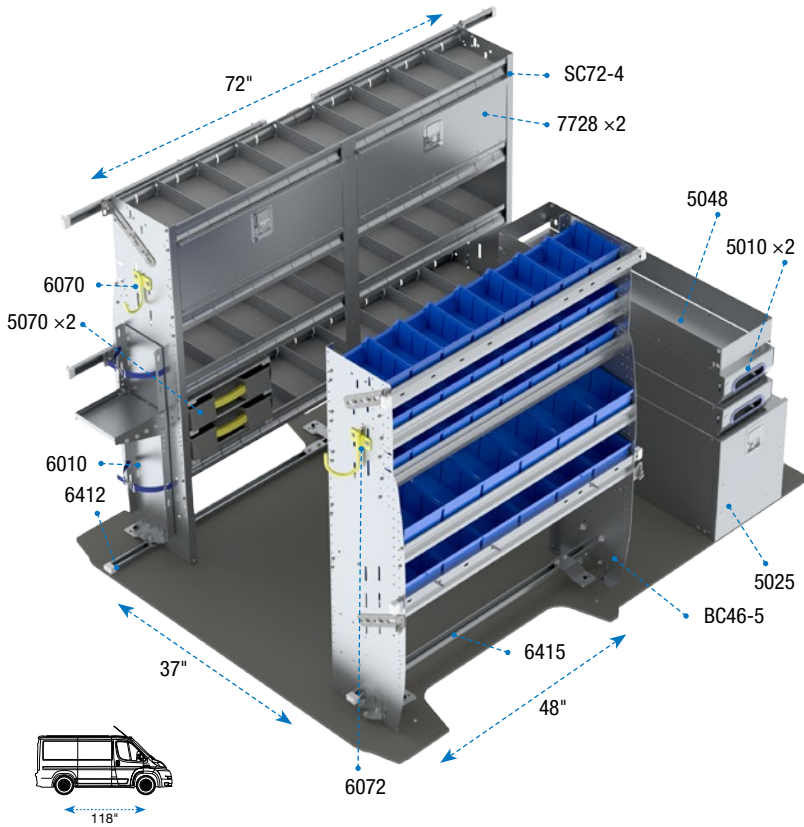

E012

HVAC Package

Aluminum

	Standard		148 lbs		2.6 hrs
	Yes				

Qty	Part #	Description
2	5010	Partslider 48" deep
1	5025	Jumbo tool drawer
1	5048	Top edge
2	5070	Partskeeper
1	6010	Two level bottle holder
1	6070	6" hook with 3" opening
1	6072	8" swivel hook with 4" opening
1	6088	Large bottle holder
1	6412	Shelving install kit, driver side
1	6415	Shelving install kit, passenger side
2	7728	Aluminum locking door
1	BC48-5	Bin shelf - 5 shelves
1	SC72-4	4 Shelf unit - 72" long

E112

HVAC Package

Aluminum

	Medium		184 lbs		3.6 hrs
	Yes				

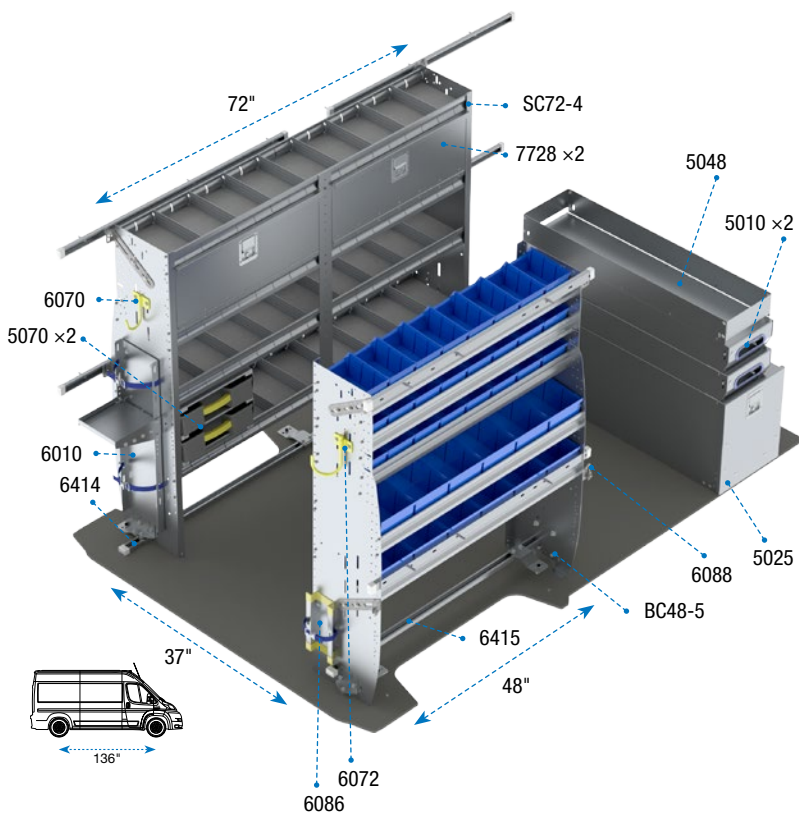

Qty	Part #	Description
2	5010	Partslider 48" deep
1	5025	Jumbo tool drawer
1	5048	Top edge
2	5070	Partskeeper
1	6010	Two level bottle holder
1	6070	6" hook with 3" opening
1	6072	8" swivel hook with 4" opening
1	6086	Small bottle holder
1	6088	Large bottle holder
1	6414	Shelving install kit, driver side
1	6415	Shelving install kit, passenger side
2	7728	Aluminum locking door
1	BC48-5	Bin shelf - 5 shelves
1	SC72-4	4 Shelf unit - 72" long

HVAC/PLUMBING CARGO VAN

ALUMINUM PACKAGES

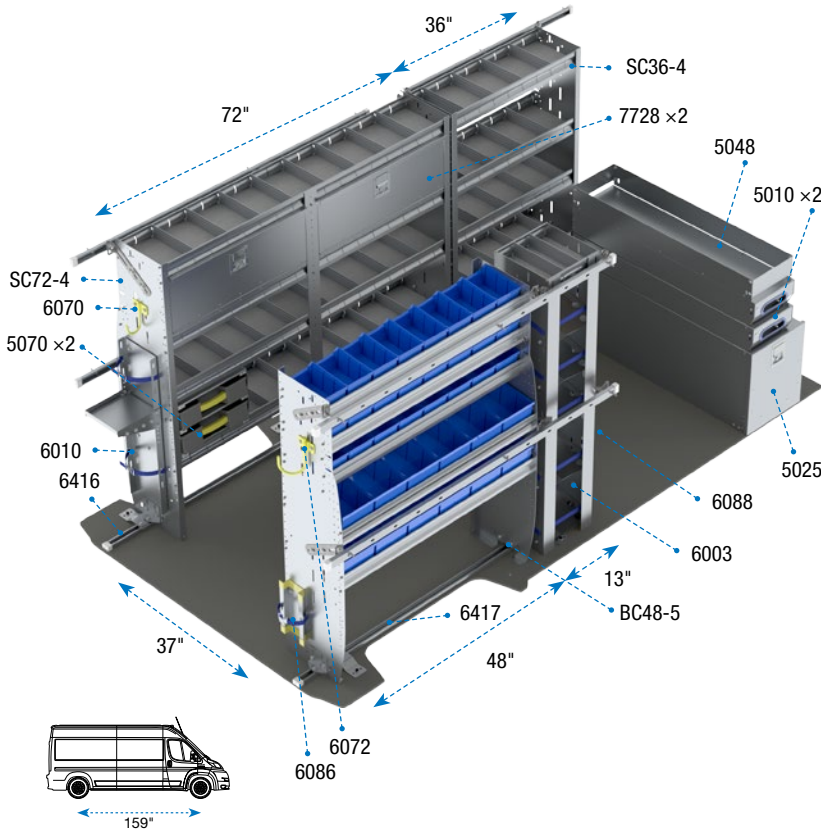

E212

HVAC Package

Aluminum

Long	215 lbs	3.8 hrs
Yes		

Qty	Part #	Description
2	5010	Partslider 48" deep
1	5025	Jumbo tool drawer
1	5048	Top edge
2	5070	Partskeeper
1	6003	5 Tier freon rack - small & large bottles
1	6010	Two level bottle holder
1	6070	6" hook with 3" opening
1	6072	8" swivel hook with 4" opening
1	6086	Small bottle holder
1	6088	Large bottle holder
1	6416	Shelving install kit, driver side
1	6417	Shelving install kit, passenger side
2	7728	Aluminum locking door
1	BC48-5	Bin shelf - 5 shelves
1	SC36-4	4 Shelf unit - 36" long
1	SC72-4	4 Shelf unit - 72" long

PACKAGES

E312

HVAC Package

Aluminum

Extended	236 lbs	3.9 hrs
Yes		

Qty	Part #	Description
2	5010	Partslider 48" deep
1	5025	Jumbo tool drawer
1	5048	Top edge
2	5070	Partskeeper
1	6003	5 Tier freon rack - small & large bottles
1	6010	Two level bottle holder
1	6070	6" hook with 3" opening
1	6072	8" swivel hook with 4" opening
1	6086	Small bottle holder
1	6088	Large bottle holder
1	6418	Shelving install kit, driver side
1	6419	Shelving install kit, passenger side
2	7728	Aluminum locking door
1	BC48-5	Bin shelf - 5 shelves
1	SC60-4	4 Shelf unit - 60" long
1	SC72-4	4 Shelf unit - 72" long

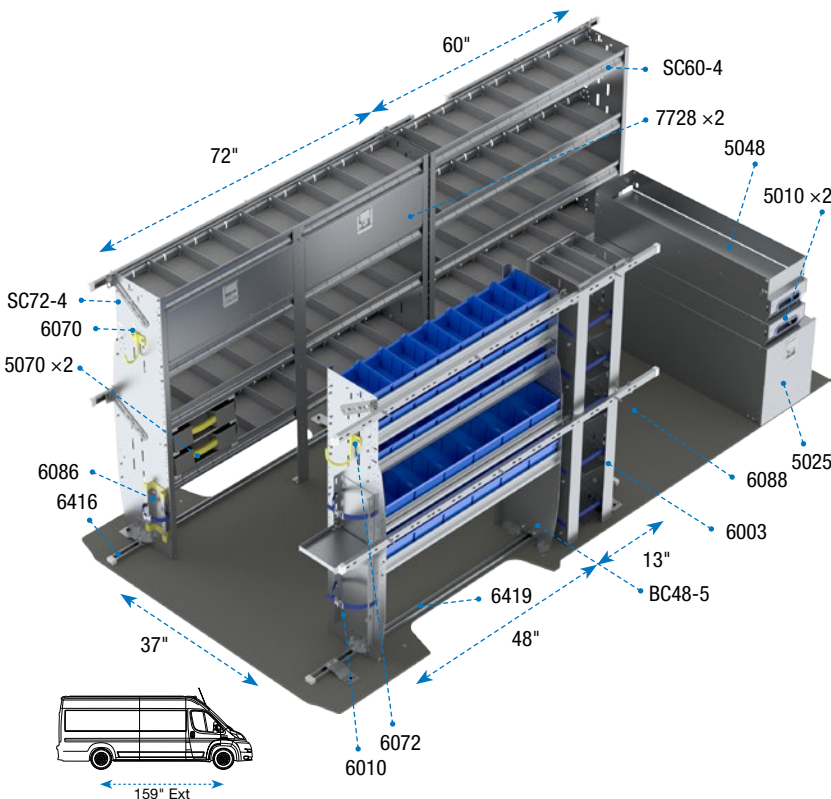

LEGEND

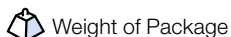



// E119 DELIVERY PACKAGE

// TOUGH

Extrusion builds durability into shelf.

// QUIET

The combination of the extrusion, shelf tray, and end-panels create durable, vibration-free shelves.

// EFFICIENT

Ergonomic design reduces injuries and increases productivity.



*Preproduction model shown,
do not use as an installation guide.

ALUMINUM PACKAGES

**DELIVERY
CARGO VAN**

PACKAGES

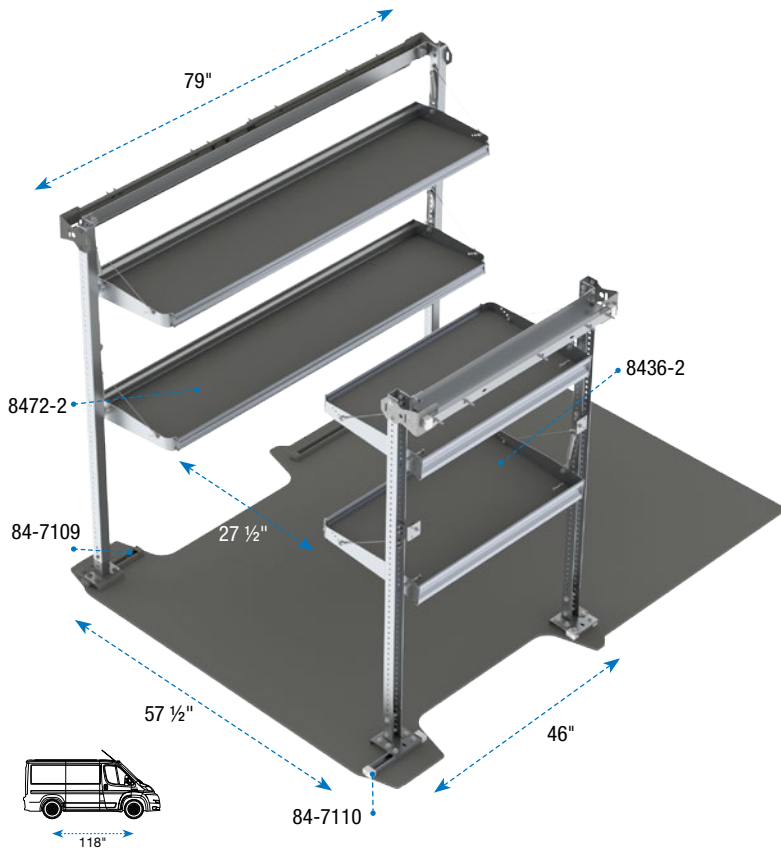

E019

Delivery Package

Aluminum

Standard	148 lbs	2.6 hrs
Yes		

Qty	Part #	Description
1	8472-2	Fold-Away Shelving Unit with 2 Levels
1	8436-2	Fold-Away Shelving Unit with 2 Levels
1	84-7109	Fold-Away install kit, driver
1	84-7110	Fold-Away install kit, passenger

**PICK YOUR
ACCESSORIES**

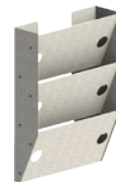

P. 42

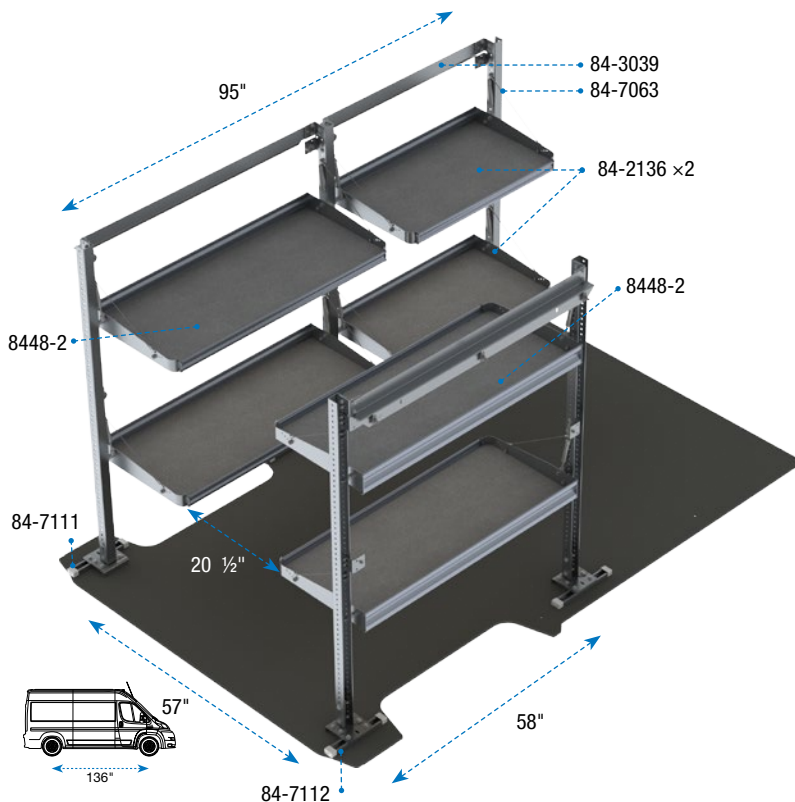

E119

Delivery Package

Aluminum

Medium	184 lbs	3.6 hrs
Yes		

Qty	Part #	Description
2	8448-2	Fold-Away Shelving Unit with 2 Levels
1	84-3039	Mounting bar, aluminum, 39", for 36" Fold-Away unit
1	84-7063	Fold-Away aluminum post with steel foot, 63.5 H
2	84-2136	Fold-Away shelf tray, 21" x 36"
1	84-7111	Fold-Away install kit, driver
1	84-7112	Fold-Away install kit, passenger

**DELIVERY
CARGO VAN**

ALUMINUM PACKAGES

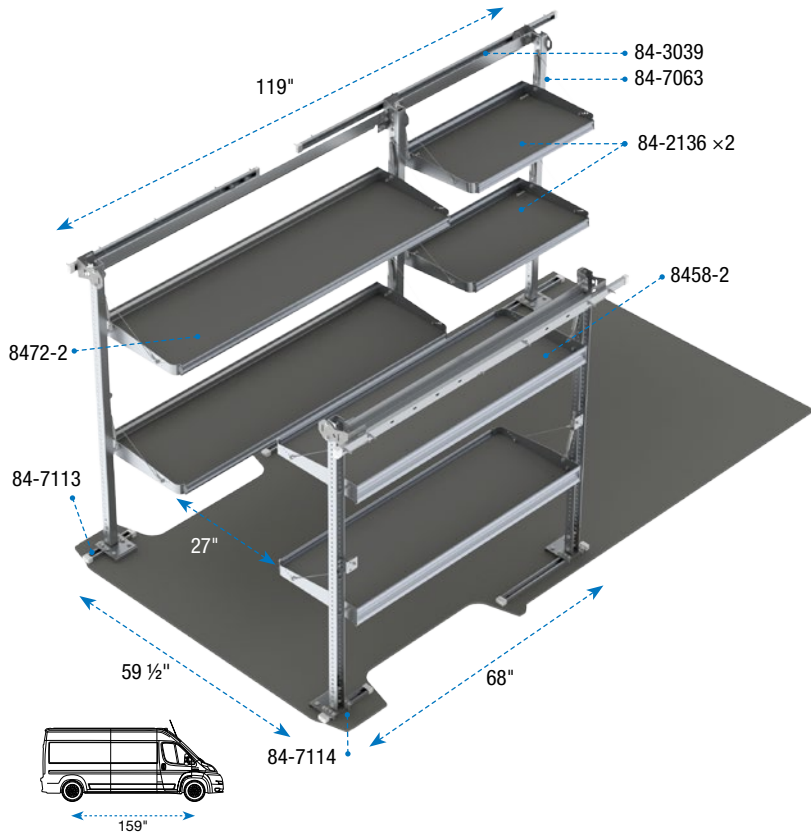

E219

Delivery Package

Aluminum

Long	215 lbs	3.8 hrs
Yes		

Qty	Part #	Description
1	8472-2	Fold-Away Shelving Unit with 2 Levels
1	8458-2	Fold-Away Shelving Unit with 2 Levels
1	84-3039	Mounting bar, aluminum, 39", for 36" Fold-Away unit
1	84-7063	Fold-Away aluminum post with steel foot, 63.5" H
2	84-2136	Fold-Away shelf tray, 21" x 36"
1	84-7113	Fold-Away install kit, driver
1	84-7114	Fold-Away install kit, passenger

PICK YOUR PARTITION



P. 8

PACKAGES

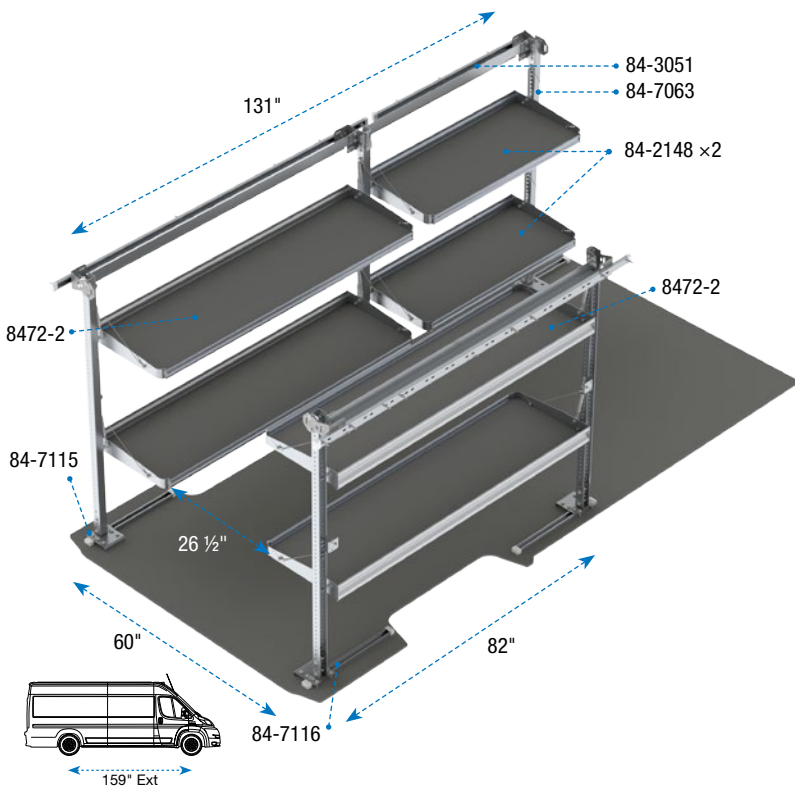

E319

Delivery Package

Aluminum

Extended	236 lbs	3.9 hrs
Yes		

Qty	Part #	Description
2	8472-2	Fold-Away Shelving Unit with 2 Levels
1	84-3051	Mounting bar, aluminum, 51", for 48" Fold-Away unit
1	84-7063	Fold-Away aluminum post with steel foot, 63.5" H
2	84-2148	Fold-Away shelf tray, 21" x 48"
1	84-7115	Fold-Away install kit, driver
1	84-7116	Fold-Away install kit, passenger

LEGEND

- Wheelbase
- Weight of Package
- Install Time
- Quickship

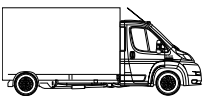
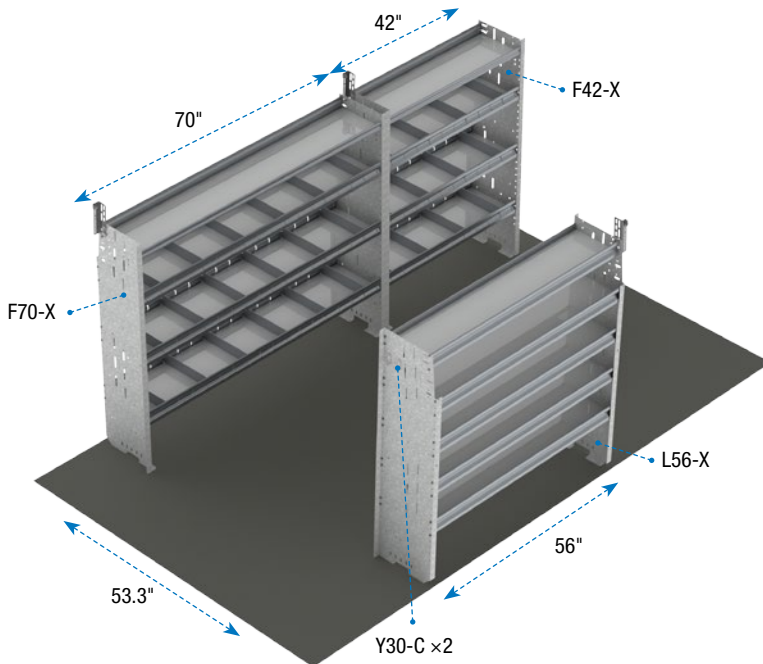

Z10-D

Contractor Package for 10'+ Box

Steel

10' +	275 lbs	3.4 hrs
No		

Qty	Part #	Description
1	F42-X	Shelf unit, square back
1	F70-X	Shelf unit, square back
1	L56-X	Shelf unit, square back
2	Y30-C	Small hook

**NEED DEEPER
SHELVING**



P. 37

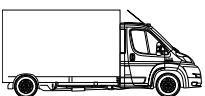
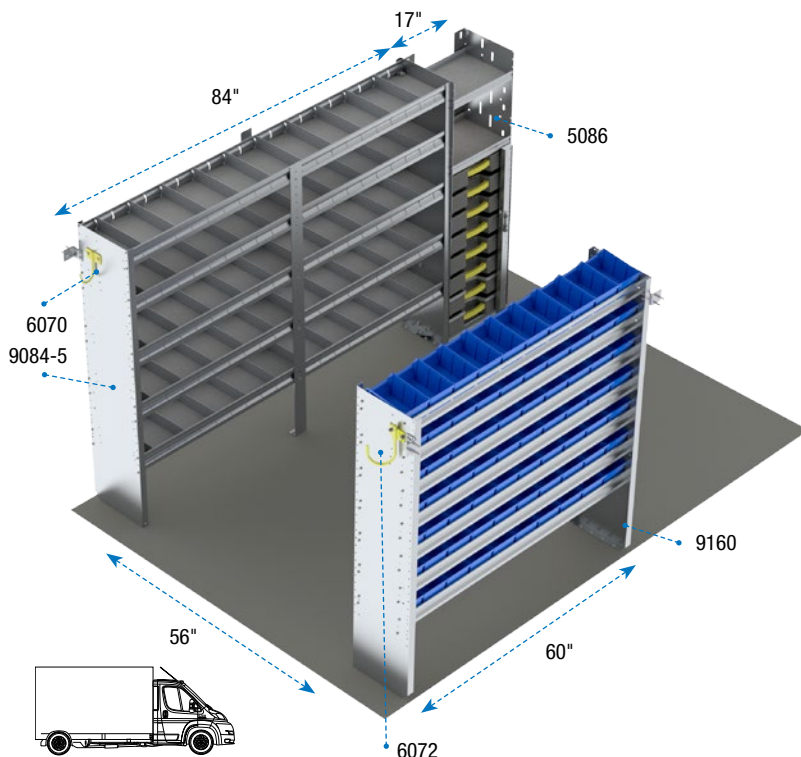

B115

HVAC/Plumbing Package for 10'+ Box

Aluminum

10' +	310 lbs	3.6 hrs
No		

Qty	Part #	Description
1	5086	Partskeeper cabinet
1	6070	6" hook with 3" opening
1	6072	8" swivel hook with 4" opening
1	9160	Bin unit, square back
1	9084-5	Shelf unit, square back

**PICK YOUR
DRAWERS**



P. 42

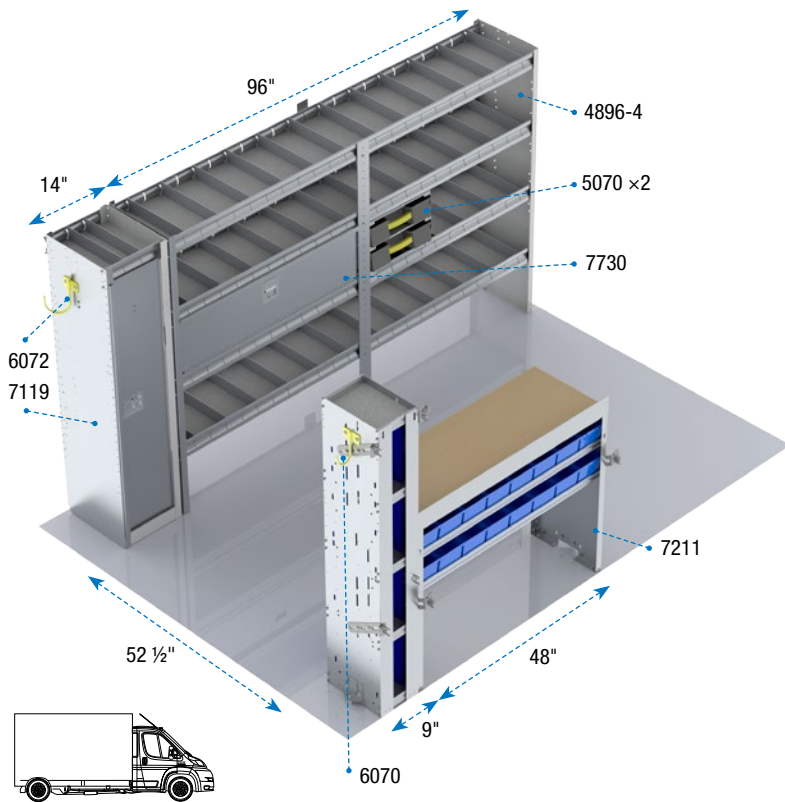

B116

Service/Locksmith Package for 10'+ Box

Aluminum

10' +	283 lbs	5.6 hrs
No		

Qty	Part #	Description
2	5070	Partskeeper, shelf mount
1	6070	6" hook with 3" opening
1	6072	8" swivel hook with 4" opening
1	7108	Bookshelf
1	7119	Locker, square back
1	7211	Workbench
1	7730	Locking door kit
1	4896-4	Shelf unit, square back

**PICK YOUR
ACCESSORIES**



P. 42

PACKAGES

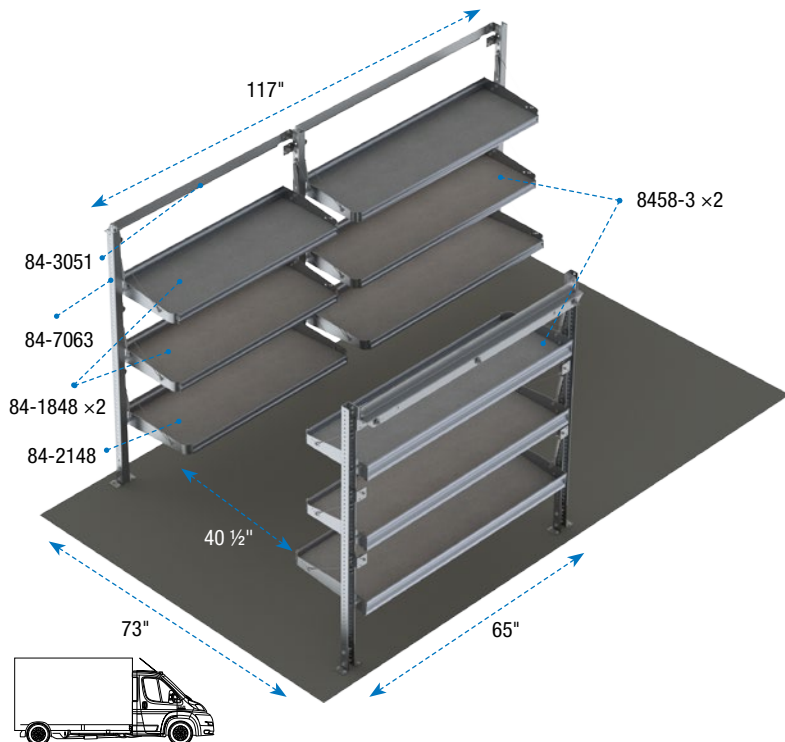

B119

Delivery Package for 10'+ Box

Aluminum

10' +	233 lbs	4.9 hrs
No		

Qty	Part #	Description
2	84-1848	Shelf tray assembly, 18" x 48", Fold-Away
1	84-2148	Shelf tray assembly, 21" x 48", Fold-Away
1	84-3051	Mounting bar assembly, 48", Fold-Away
2	8458-3	Shelf unit, Fold-Away
1	84-7063	Post assembly, 63.5" H, Fold-Away

SHELVING

Industry leading strength.
The perfect fit for the toughest jobs.

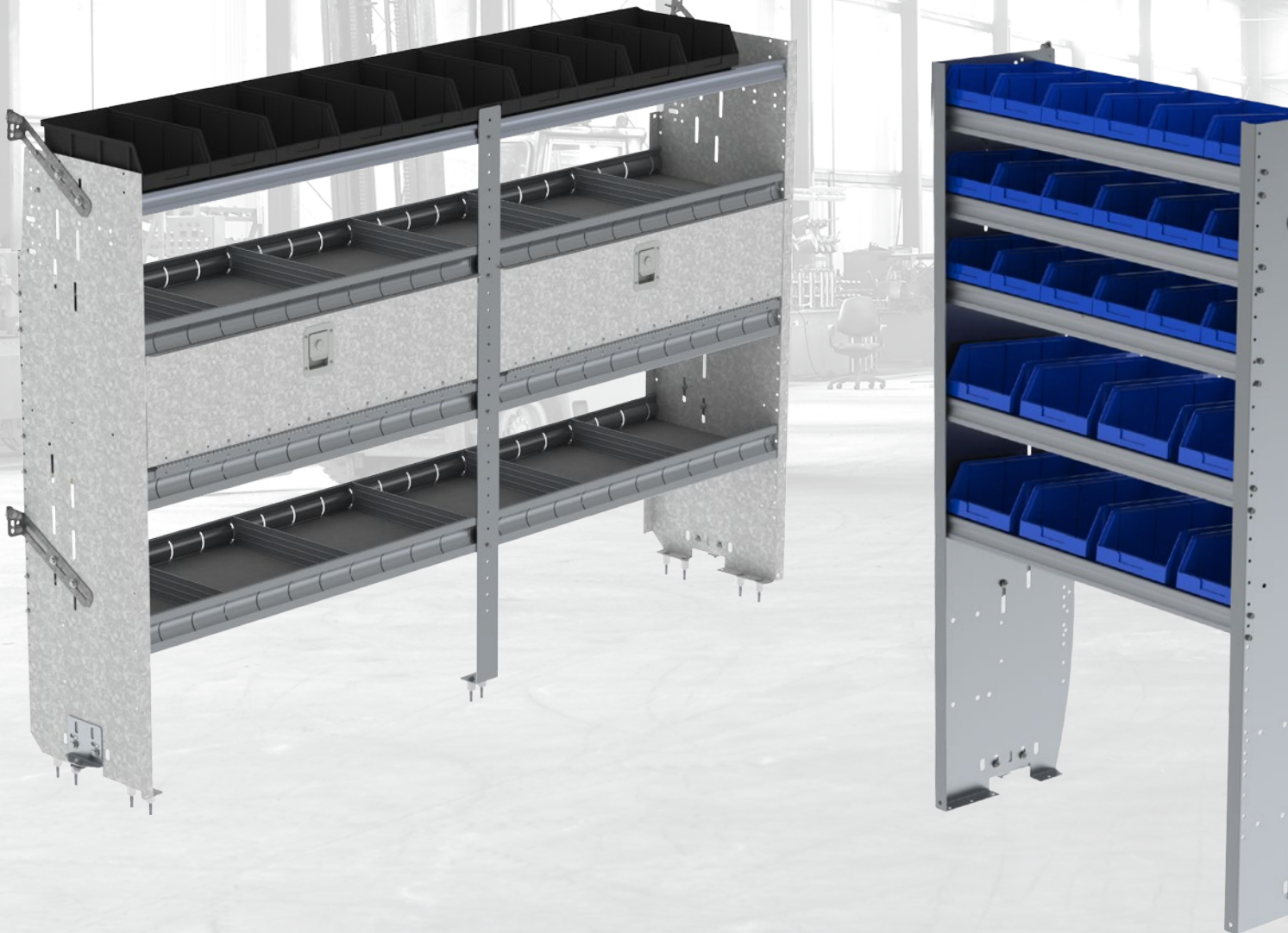

BENEFIT

Ranger Design shelving is built strong and durable, often outlasts the vehicle and can be transferred to a newer van or truck. Designed to fit with maximum efficiency, Ranger shelving optimizes the space in a work van's cargo area.



TOUGH
Extrusion builds durability into shelf



QUIET
Shelf tray, end panel and extrusion are engineered to be vibration free



EFFICIENT
Ergonomics reduce injuries and increase productivity

SHELVING INSTALL KITS

Using our installation kit means your Ranger shelving package can be installed in your ProMaster using factory mounting points, avoiding the need to drill and make holes in the van to attach installation brackets. This prevents rust and conserves your vehicle's resale value.



Product #	ProMaster Short	ProMaster Medium
All Shelving, Lockers and Drawers Driver side	6412	6414
All Shelving Passenger side	6413	6415
All Fold-Away Shelving Driver side	84-7109	84-7111
All Fold-Away Shelving Passenger side	84-7110	84-7112



Product #	ProMaster Long	ProMaster Extended
All Shelving, Lockers and Drawers Driver side	6416	6418
All Shelving Passenger side	6417	6419
All Fold-Away Shelving Driver side	84-7113	84-7115
All Fold-Away Shelving Passenger side	84-7714	84-7116



SHELVING

Contoured Bin Shelving Unit

Aluminum



BC36-5	36" W x 62.5" H	99 lbs			18 (md), 8 (lrg)	1.4 hrs	No
BC48-5	48" W x 62.5" H	123 lbs			24 (md), 12 (lrg)	1.4 hrs	No
BC60-5	60" W x 62.5" H	143 lbs			30 (md), 14 (lrg)	1.4 hrs	No

Contoured Refrigerant Bin Unit

Aluminum



RC48	48" W x 62.5" H	106 lbs			24 (md)	1.2 hrs	Yes
RC60	60" W x 62.5" H	120 lbs			30 (md)	1.2 hrs	Yes

Contoured Shelving Unit with Dividers

Aluminum









SC36-4	15.5" D x 36" W x 62.5" H	46 lbs		4 Shelves (11", 12", 13", 13")	30	7733	1.2 hrs	Yes
SC48-4	15.5" D x 48" W x 62.5" H	56 lbs		4 Shelves (11", 12", 13", 13")	24	7730	1.2 hrs	Yes
SC60-4	15.5" D x 60" W x 62.5" H	66 lbs		4 Shelves (11", 12", 13", 13")	32	7732	1.2 hrs	Yes
SC72-4	15.5" D x 72" W x 62.5" H	76 lbs		4 Shelves (11", 12", 13", 13")	40	7733	1.4 hrs	Yes
SC84-4	15.5" D x 84" W x 62.5" H	88 lbs		4 Shelves (11", 12", 13", 13")	40	N/A	1.4 hrs	No
SC96-4	15.5" D x 96" W x 62.5" H	98 lbs		4 Shelves (11", 12", 13", 13")	48	7730	1.4 hrs	Yes



Contoured Shelving Unit with Dividers

Aluminum







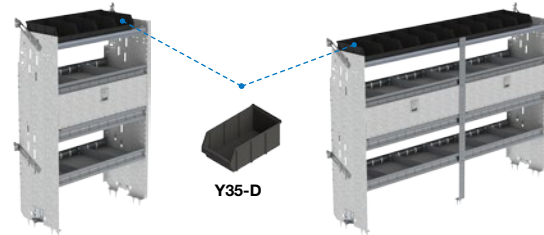

							
SC36-5	15.5" D x 36" W x 62.5" H	53 lbs	5 Shelves (11", 11", 13", 13", 13")	30	7723	1.2 hrs	No
SC48-5	15.5" D x 48" W x 62.5" H	65 lbs	5 Shelves (11", 11", 13", 13", 13")	30	7720	1.2 hrs	No
SC60-5	15.5" D x 60" W x 62.5" H	78 lbs	5 Shelves (11", 11", 13", 13", 13")	12	7722	1.2 hrs	No
SC72-5	15.5" D x 72" W x 62.5" H	90 lbs	5 Shelves (11", 11", 13", 13", 13")	50	7723	1.4 hrs	Yes
SC84-5	15.5" D x 84" W x 62.5" H	102 lbs	5 Shelves (11", 11", 13", 13", 13")	50	N/A	1.4 hrs	No
SC96-5	15.5" D x 96" W x 62.5" H	118 lbs	5 Shelves (11", 11", 13", 13", 13")	60	7720	1.4 hrs	No

Deep Square Back Bin Shelving Unit

Steel







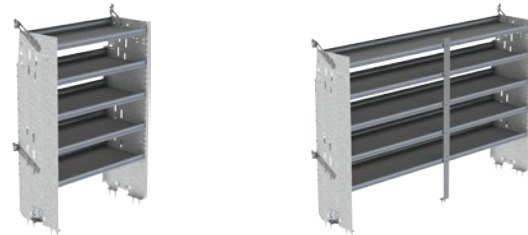

							
H38-T	17" D x 38" W x 58" H	93 lbs	4 Shelves (14", 16", 16", 16")	6	4 (lrg)	1 hr	No
H42-T	17" D x 42" W x 58" H	100 lbs	4 Shelves (14", 16", 16", 16")	6	5 (lrg)	1 hr	No
H56-T	17" D x 56" W x 58" H	120 lbs	4 Shelves (14", 16", 16", 16")	12	7 (lrg)	1 hr	No
H70-T	17" D x 70" W x 58" H	140 lbs	4 Shelves (14", 16", 16", 16")	12	8 (lrg)	1 hr	No
H87-T	17" D x 87" W x 58" H	165 lbs	4 Shelves (14", 16", 16", 16")	15	10 (lrg)	1 hr	No

Deep Square Back Shelving Unit

Steel



							
L38-T	17" D x 38" W x 58" H	88 lbs				1 hr	No
L42-T	17" D x 42" W x 58" H	93 lbs				1 hr	No
L56-T	17" D x 56" W x 58" H	112 lbs				1 hr	No
L70-T	17" D x 70" W x 58" H	130 lbs				1 hr	No
L87-T	17" D x 87" W x 58" H	154 lbs				1 hr	No

SHELVING



Deep Square Back Shelving Unit with Dividers

Steel

F38-T	17" D x 38" W x 58" H	80 lbs	4 Shelves (14", 16", 16", 16")	6	Y11-D	1 hr	No
F42-T	17" D x 42" W x 58" H	85 lbs	4 Shelves (14", 16", 16", 16")	6	Y11-F	1 hr	No
F56-T	17" D x 56" W x 58" H	101 lbs	4 Shelves (14", 16", 16", 16")	12	Y11-J	1 hr	No
F70-T	17" D x 70" W x 58" H	115lbs	4 Shelves (14", 16", 16", 16")	12	Y11-C	1 hr	No
F87-T	17" D x 87" W x 58" H	136 lbs	4 Shelves (14", 16", 16", 16")	15	Y11-F	1 hr	No

SHELVING

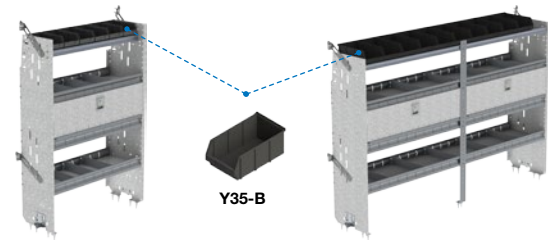

Square Back Bin Shelving Unit

Steel

H38-X	14" D x 38" W x 58" H	80 lbs	4 Shelves (9", 13", 13", 13")	9	6 (md)	1 hr	No
H42-X	14" D x 42" W x 58" H	86 lbs	4 Shelves (9", 13", 13", 13")	9	7 (md)	1 hr	No
H56-X	14" D x 56" W x 58" H	103 lbs	4 Shelves (9", 13", 13", 13")	12	9 (md)	1 hr	No
H70-X	14" D x 70" W x 58" H	120 lbs	4 Shelves (9", 13", 13", 13")	12	11 (md)	1 hr	No
H87-X	14" D x 87" W x 58" H	145 lbs	4 Shelves (9", 13", 13", 13")	18	14 (md)	1 hr	No

Square Back Bin Shelving Unit

Aluminum









7848	11" D x 48" W x 13.25" H	25 lbs		16 (md)		0.5 hr	No



Square Back Shelving Unit

Steel









							
L38-X	14" D x 38" W x 58" H	78 lbs	5 Shelves (11", 13", 13", 13", 13")			1 hr	Yes
L42-X	14" D x 42" W x 58" H	82 lbs	5 Shelves (11", 13", 13", 13", 13")			1 hr	Yes
L56-X	14" D x 56" W x 58" H	99 lbs	5 Shelves (11", 13", 13", 13", 13")			1 hr	Yes
L70-X	14" D x 70" W x 58" H	115 lbs	5 Shelves (11", 13", 13", 13", 13")			1 hr	No
L87-X	14" D x 87" W x 58" H	141 lbs	5 Shelves (11", 13", 13", 13", 13")			1 hr	No

Square Back Shelving Unit with Dividers

Steel



							
F38-X	14" D x 38" W x 58" H	70 lbs	4 Shelves (11", 14", 14", 14")	9	Y12-D	1 hr	No
F42-X	14" D x 42" W x 58" H	74 lbs	4 Shelves (11", 14", 14", 14")	9	Y12-F	1 hr	Yes
F56-X	14" D x 56" W x 58" H	88 lbs	4 Shelves (11", 14", 14", 14")	12	Y12-J	1 hr	Yes
F70-X	14" D x 70" W x 58" H	102 lbs	4 Shelves (11", 14", 14", 14")	12	Y12-C	1 hr	Yes
F87-X	14" D x 87" W x 58" H	125 lbs	4 Shelves (11", 14", 14", 14")	18	Y12-F	1 hr	Yes



RANGER DEEP SHELVING

P. 37

Ranger Design deep shelving helps you increase the cargo capacity of your work van.

H87-T Deep Square Back Bin Shelving Unit









SHELVING



Fold-Away Shelving

Aluminum

							
8436-2	21" D x 36" W x 63.5" H	42 lbs	2 Shelves (20", 20")				No
8448-2	21" D x 55" W x 63.5" H	58 lbs	2 Shelves (20", 20")			1.2 hrs	Yes
8458-2	21" D x 65" W x 63.5" H	64 lbs	2 Shelves (20", 20")			1.3 hrs	Yes
8472-2	21" D x 79" W x 63.5" H	74 lbs	2 Shelves (20", 20")			1.4 hrs	Yes







*Weight capacity for fold-away shelving is 65 lbs / linear foot.

SHELVING



Fold-Away Shelving

Aluminum

							
8448-3	21" D x 55" W x 63.5" H	74 lbs	3 Shelves (17", 17", 20")			1.6 hrs	No
8458-3	21" D x 65" W x 63.5" H	83 lbs	3 Shelves (17", 17", 20")			1.7 hrs	No
8472-3	21" D x 79" W x 63.5" H	98 lbs	3 Shelves (17", 17", 20")			1.8 hrs	Yes

*Weight capacity for fold-away shelving is 65 lbs / linear foot.

HAVEN'T FOUND THE SHELVING UNIT THAT YOU WOULD LIKE?

Consult our 2015 Buyers' Guide online at www.rangerdesign.com





RANGER PACKAGES

Get more out of your work van: Ranger packages are designed specifically with your trade in mind. Our aim is to ensure that your most frequently used tools and equipment are well within reach.

Do you see a way that we can improve our packages? We appreciate your feedback! Contact our customer service team at **1-800-565-5321**.



Z16-E1 Package



DRAWERS & ACCESSORIES

Choose the finishing details to tailor the upfit to your specific needs





TOUGH

Aluminum drawers are backed by a 10 year warranty.



QUICK

Easy to use slam latch.



SECURITY

Secure keyed lock.

DRAWERS & ACCESSORIES

- CAB BOXES P. **43**
- DRAWER CABINETS. P. **43**
- PARTSKEEPERS P. **44**
- TOOL DRAWERS P. **44**
- BOTTLE HOLDERS P. **45**
- HOOKS P. **45**
- PAPER HOLDERS P. **46**
- OTHERS P. **46**
- WINDOW GRILLS P. **47**

Ranger manufactures a variety of tough, quiet drawer systems and storage modules.

Using top quality components such as full-extension, high-capacity ball-bearing drawer slides, secure locks, and Ranger's unique braided stainless steel cable-pull handles. These drawers are the organizational quality that you deserve.

If you never again want to experience the frustration of drawers that jam, sag, and don't latch properly, we have the solution.

The finishing details are just as important when you're setting up your commercial van as they are when you're on the job site. Customize your vehicle with our wide range of options to ensure that you can perform at peak efficiency.



DRAWERS & ACCESSORIES



5045

Cab box with locking lid

Aluminum

18" D x 12" W x 16" H

16 lbs

0.4 hr

No



5047

Raised base for ProMaster cab box

Aluminum

4 lbs

0.2 hr

No



W40-A

Fleetline cab box with locking lid

Steel

18" D x 12" W x 16" H

22 lbs

0.4 hr

No



5060-6

6 Drawer cabinet

Aluminum

18" D x 24" W x 36" H

150 lbs / Drawer

114 lbs

1 hr

No



5066-8

8 Drawer cabinet

Aluminum

20.5" D x 24" W x 56" H

150 lbs / Drawer

168 lbs

1 hr

No



5069-2

2 Drawer cabinet

Aluminum

14" D x 24" W x 12" H

150 lbs / Drawer

34 lbs

0.5 hr

Yes



X50-B

Compact 2-Drawer Unit

Steel

12.5" D x 19" W x 10.5" H

20 lbs / Drawer

19 lbs

0.3 hr

Yes



X50-C

Compact 3-Drawer Unit

Steel

12.5" D x 19" W x 10.5" H

20 lbs

0.3 hr

Yes

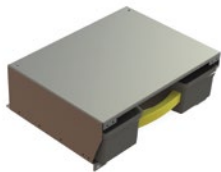

5070

Partskeeper carry case with holder, universal

Aluminum

14" D x 17" W x 5.5" H

7 lbs

0.3 hr

Yes



5086

Partskeeper cabinet with 8 carry cases & 2 shelves

Aluminum

14" D x 17" W x 62.5" H

57 lbs

1 hr

Yes



5010

Partslider drawer

Aluminum

48" D x 12" W x 6" H

150 lbs

30 lbs

0.5 hr

Yes



5020

Tool drawer

Aluminum

48" D x 14" W x 16" H

320 lbs

46 lbs

1 hr

Yes

DRAWERS & ACCESSORIES



5025

Jumbo tool drawer

Aluminum

48" D x 16" W x 19" H

320 lbs

61 lbs

1 hr

Yes



5048

Top edge, for 5010 Partslider

Aluminum

48" D x 12" W x 4" H

5 lbs

0.2 hr

Yes



X51-F

Fleetline drawer unit with 9 divided drawers

Steel

12" D x 17" W x 12" H

26 lbs

0.3 hr

No



6001

4 Tier refrigerant rack for large bottles

Aluminum

14" D x 13" W x 62.5" H

34 lbs

0.7 hr

No

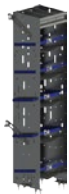

6003

5 Tier refrigerant rack for 2 large & 3 small bottles

Aluminum

14" D x 13" W x 62.5" H

36 lbs

0.7 hr

Yes



6010

Two level adjustable bottle holder

Aluminum

10.25" D x 9.5" W x 36" H

5 lbs

0.4 hr

No

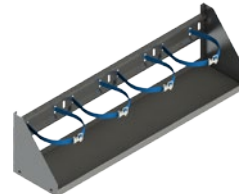

6020

Horizontal refrigerant bottle holder

Aluminum

12.5" D x 48" W x 13" H

17 lbs

0.5 hr

No



6041

Locking cabinet

Aluminum

15" D x 15.5" W x 33" H

26 lbs

0.7 hr

No



6086

Small bottle/tank holder comes with a blue nylon strap

Aluminum

6" W x 12" H

1 lb

0.2 hr

Yes



6088

Large bottle/tank holder comes with a blue nylon strap

Aluminum

8" W x 24" H

2 lbs

0.2 hr

Yes



6070

6" Hook, 3" opening, painted

Aluminum

3" D

0.4 lb

0.2 hr

Yes



6072

8" Swivel Hook, 4" opening, tumbled

Aluminum

0.6 lb

0.2 hr

Yes

DRAWERS & ACCESSORIES



6073

Large aluminum movable hook, 6.5" opening

Aluminum

	6.5" D x 2.75" W x 4" H
	1 lb
	0.01 hr
	Yes



Y30-C

Coat Hook, 1" opening, chrome plated

Steel

	1" D
	0.1 lb
	0.2 hr
	Yes



6061

2-Slot Paper Holder

Aluminum

	3.75" D x 12.75" W x 12" H
	2 lbs
	0.2 hr
	No



6063

5-Slot Paper Holder

Aluminum

	3.75" D x 12.75" W x 24" H
	5 lbs
	0.2 hr
	Yes



6068

Hard Hat Holder, painted wire

Steel

	0.5 lb
	0.2 hr
	No

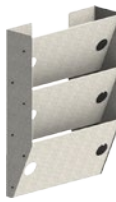

Y31-A

3 Slot paper holder

Steel

	3.75" D x 12.75" W x 16" H
	9 lbs
	0.2 hr
	Yes



1130

Elevated strobe mount

Aluminum

	8" W
	1 lb
	0.1 hr
	No



6050

Flettner vent, rotary design

Other

	48" W
	1.5 lbs
	1 hr
	No



6052

Vise Holder with an 8" x 8" mounting plate

Steel

	37 lbs
	0.5 hr
	No



6054

Hitch Step, comes with hitch pin to fit a 2" x 2" hitch

Aluminum

	6" D x 12" W
	4 lbs
	No

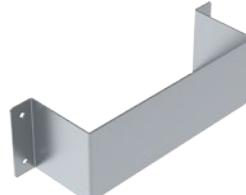

6057

Can Holder

Aluminum

	3" D x 8.5" W x 3" H
	1 lb
	0.2 hr
	No

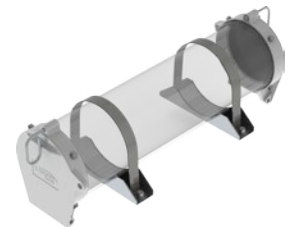

6079

Transport tube door kit complete

Aluminum

	6" D
	6 lbs
	0.8 hr
	No

DRAWERS & ACCESSORIES



6082

Triangle kit with aluminum holder

Other

	14 lbs
	0.2 hr
	No



6093

Grab handle

Plastic

	9.5" D
	0.1 lb
	0.5 hr
	No



7124

Reel Holder with two 5/8" diameter rods

Aluminum

	7.25" D x 15" W x 24" H
	9 lbs
	0.5 hr
	No



6118

ProMaster window grill, passenger side sliding door

Steel

	8 lbs
	0.2 hr
	No

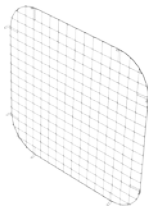

6119

Set of 2 ProMaster rear window grills

Steel

	8 lbs
	0.2 hr
	No



DRAWERS & ACCESSORIES

HAVEN'T FOUND WHAT YOU'RE LOOKING FOR?



MANY MORE ACCESSORIES AVAILABLE!

Call Toll-Free at **1 (800) 565-5321**
or visit us online at www.rangerdesign.com



LADDER RACKS

Ergonomic Ladder Racks make loading and unloading easier





TOUGH

Military grade aluminum extrusion, high density plastic and stainless steel components ensure no corrosion over the lifetime of the rack.



QUIET

Aerodynamic design with minimal wind noise.



SAFE

No metal contact to ladder, leading to longer life of ladders with less chance of fiberglass splinters.

LADDER RACKS

Ranger ladder racks make loading and unloading ladders an easy operation.

Ranger Design offers drop-down ladder racks for high roof vans, extra tough racks capable of carrying 28' ladders on compact vans, interior ladder carriers and many other options for different applications.

Cargo rack

Aluminum



1505-PH	Universal	72"	480 lbs	0.8 hr	18 lbs

Combination ladder rack

Aluminum



1525-PHL	Long			1.7 hrs	43 lbs
1525-PHM	Medium			1.7 hrs	43 lbs
1525-PHS	Short			1.7 hrs	43 lbs
1525-PHX	Extended			1.7 hrs	43 lbs

Max Rack, Single side ladder rack

Aluminum



1820-PHL	Long		100 lbs	N/A	
1820-PHM	Medium		100 lbs	N/A	
1820-PHS	Short		100 lbs	N/A	
1820-PHX	Extended		100 lbs	N/A	

LADDER RACKS

Max Rack, Double side ladder rack

Aluminum



1830-PHL	Long	200 lbs	N/A		
1830-PHM	Medium	200 lbs	N/A		
1830-PHS	Short	200 lbs	N/A		
1830-PHX	Extended	200 lbs	N/A		

Access Pro inside ladder carrier

Aluminum



1050-FS	Universal	96"	1 hr	9 lbs	

Step-Ladder attachment kit

Aluminum



1127	Universal		0.5 hr	18 lbs	

Third bar crossbow kit

Aluminum



15-1805	Universal	72"			

Additional bar upgrade kit

Aluminum



15-0527	Universal	72"			



RANGER LADDER RACKS

Upgrade your ladder rack with the addition of this third or fourth bar.

15-0527 Additional bar upgrade kit



MAX RACK DESIGNED FOR HIGH ROOF VANS

LADDER RACKS

SAFE & EASY TO USE

50" OF TRAVEL

The Max Rack drops lower in one stage than any other rack in the industry.

- Max Rack
- Competitor's rack

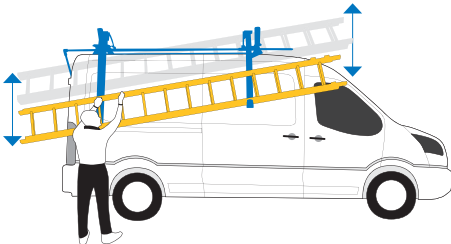

- › Two pressurized gas shocks support the weight of the ladder and assist in lifting and lowering the ladder and also holds it in the closed position.
- › Max Rack is adjustable to fit most ladders.

LOW PROFILE

There is less chance of the Max Rack hitting low hanging objects.



- › Ladder only touches composite materials, reducing wear on the ladders.
- › Comes down in one single motion.

CYCLE TESTING

The Max Rack completed over 4300 cycles, which represents up to 15 years of use.



EXTREME WEATHER PROOF

The Max Rack was put through extreme weather testing.

HOW TO ORDER



OVER 300 DISTRIBUTORS ACROSS THE CONTINENT

REGULAR ORDER

QUICKSHIP ORDER

How to Order

Contact one of our 300 distributors
rangerdesign.com/find-dealer.

Ranger Quickship service is available
through your local distributor.

Lead Time

Orders ship from our factory
5 business days upon placing your
order to transit to your distributor.

Orders placed with Ranger before 1PM EST
will ship from our factory in the next business
day to transit to your distributor.



Throughout the catalog products and packages with this symbol can be ordered through our **Quickship** service.



TURN-KEY FLEET SERVICES

**SHIP THROUGH OR LOCAL INSTALLATION
ACROSS NORTH AMERICA
FOR ALL TYPES OF RAM CARGO VANS**

1. ANALYSIS

- › Cargo Needs Analysis
- › Custom 3D CAD Layouts
- › Hands-on Equipment Demo

2. TESTING

- › Test Fitting
- › Pilot Build and Review
- › Optimize Package Based on Technician Feedback

3. DELIVERY

- › Delivery, Production and Installation Planning and Scheduling
- › Vehicle Status Tracking

4. SERVICE

- › Dedicated Fleet Account Management Team
- › 300 Ranger Dealers Service Support Network
- › Live Customer Service



**CONTACT RANGER
FLEET SERVICES AT:**
fleet@rangerdesign.com
1-800-565-5321

INDEX

1050-FS.....	50	6054	46	E019.....	30	L87-T	37
1127	50	6057.....	46	E111	24	L87-X	39
1130.....	46	6061.....	46	E112.....	26	RC48	36
15-0527	50	6063	46	E119.....	30	RC60	36
15-1805	50	6068	46	E211.....	25	SC36-4	36
1505-PH.....	49	6070.....	45	E212.....	27	SC36-5	37
1525-PHL.....	49	6072.....	45	E219.....	31	SC48-4	36
1525-PHM	49	6073.....	46	E311.....	25	SC48-5	37
1525-PHS	49	6079.....	46	E312.....	27	SC60-4	36
1525-PHX.....	49	6082	47	E319.....	31	SC60-5	37
1820-PHL.....	49	6086	45	F38-T	38	SC72-4.....	36
1820-PHM	49	6088	45	F38-X	39	SC72-5.....	37
1820-PHS	49	6093	47	F42-T	38	SC84-4	36
1820-PHX	49	6118.....	47	F42-X	39	SC84-5	37
1830-PHL.....	50	6119.....	47	F56-T	38	SC96-4	36
1830-PHM	50	6520.....	11	F56-X	39	SC96-5	37
1830-PHS	50	6521.....	11	F70-T	38	W40-A	44
1830-PHX	50	6522.....	11	F70-X	39	X50-B.....	44
3020-RP	9	6523.....	11	F87-T	38	X50-C	44
3068-RP	9	7124	47	F87-X	39	X51-F	45
5010.....	44	7848.....	38	H38-T.....	37	Y30-C	46
5020.....	44	8436-2.....	40	H38-X.....	38	Y31-A.....	46
5025.....	45	8448-2.....	40	H42-T.....	37	Z10-D.....	32
5045	44	8448-3.....	40	H42-X.....	38	Z10-E0.....	16
5047.....	44	8458-2.....	40	H56-T.....	37	Z10-E1	16
5048	45	8458-3.....	40	H56-X.....	38	Z10-E2.....	17
5060-6.....	44	8472-2.....	40	H70-T.....	37	Z10-E3.....	17
5066-8.....	44	8472-3.....	40	H70-X.....	38	Z16-E0.....	20
5069-2.....	44	B115.....	32	H87-T.....	37	Z16-E1	20
5070.....	44	B116.....	33	H87-X.....	38	Z16-E2.....	21
5086	44	B119.....	33	L38-T	37	Z16-E3.....	21
6001.....	45	BC36-5	36	L38-X	39		
6003	45	BC48-5	36	L42-T	37		
6010.....	45	BC60-5	36	L42-X	39		
6020.....	45	C20-X.....	9	L56-T	37		
6041.....	45	C30-X.....	9	L56-X.....	39		
6050	46	E011.....	24	L70-T	37		
6052.....	46	E012.....	26	L70-X	39		



NEED HELP WITH YOUR ORDER

Contact us at cs@rangerdesign.com
or call **1-800-565-5321**

Ask us for our other RAM product related catalogs.



THE PERFECT FIT FOR
YOUR TOUGHEST JOBS



CUSTOMER SERVICE

cs@rangerdesign.com

1-800-565-5321

www.rangerdesign.com

