

Equipment for Commercial Vehicles



Nissan NV200 **PACKAGE CATALOG**



ACCELERATE YOUR
BUSINESS WITH
RANGER
QUICKSHIP

RANGER
DESIGN

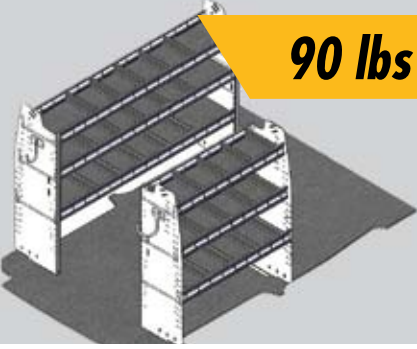

90 lbs

Contractor P 3/6
Packages



110 lbs

Service P 7/10
Packages

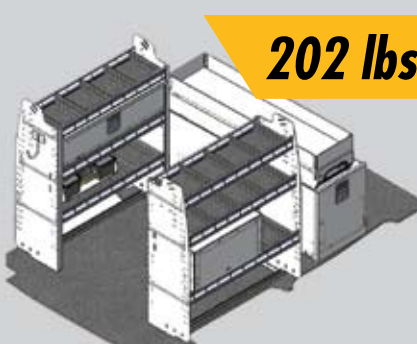

202 lbs

Electrical P 11/14
Packages



In 1988 a small family business with passion for innovation and service began to build equipment for commercial vehicles. Now with factories in Rochester NY and Montreal Canada, and a strong network of dealers across North America, Ranger Design services all trades and the same values still drive the company today.

In our modern fast-paced world, Ranger combines old-fashioned service with state of the art technology to bring you consistent quality and strength to meet the toughest demands. This is why more Tradesmen and Fleets across the nation are turning to Ranger solutions for shelving units, storage systems, partitions and ladder racks to answer their unique needs. Contact us today and experience the Ranger difference yourself!

- The Ranger Team



Drawer Systems



Shelving



Fold-Away Shelving



90 lbs

Delivery P 15/18
Packages



Parts Index P 19/20



Accessories P 21/22

RANGER DESIGN PROVIDES THE POWER OF 24-HOUR SHIPPING

to get you on the road to success faster than ever! Ranger **QUICKSHIP** 🚚 guarantees that all NV200 packages ordered with the **QUICKSHIP** 🚚 service will ship within 24 hours if ordered before 1PM. Visit our website www.rangerquickship.com for ordering details or contact one of our Customer Service representatives at cs@rangerdesigninc.com.



Quiet
A peaceful ride with no rattles



Quick
Fastest lead times in the industry



Tough
For the toughest



Payload
Engineered to save weight



Bin Shelving



Ladder Racks



Partitions



W010 Base Contractor Package Shown



CONTRACTOR Packages

Base Steel Contractor Package

RANGER
FLEETLINE

Z10-BW

Note:
Drill-free installation.

Choose your own partition!
(Partition not included in pkg.)

**TOUGH
JOBS,
TOUGH
TOOLS**

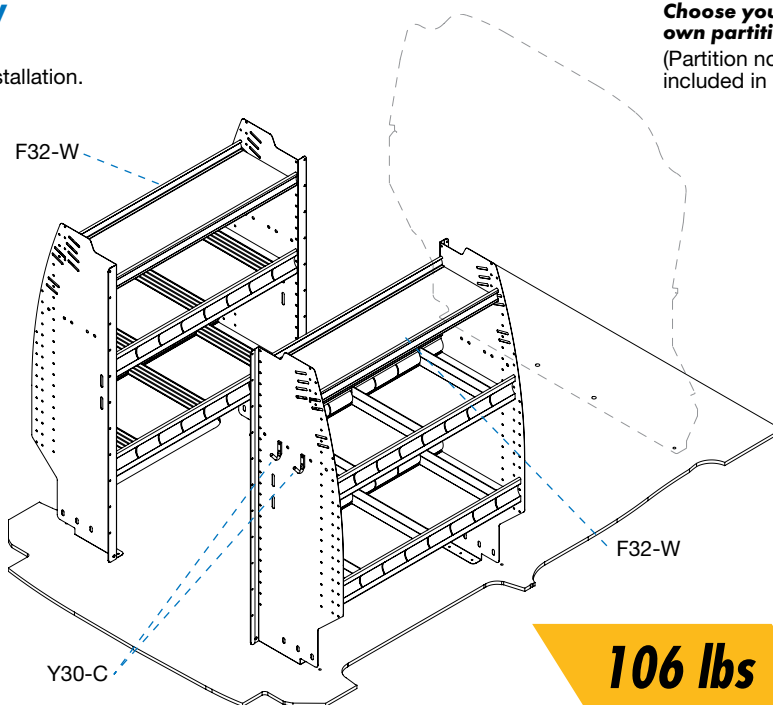

106 lbs

Base Aluminum Contractor Package

RANGER
PROLINE

W010

Note:
Drill-free installation.

Choose your own partition!
(Partition not included in pkg.)



W010 Package shown with a 3020-NS window partition.

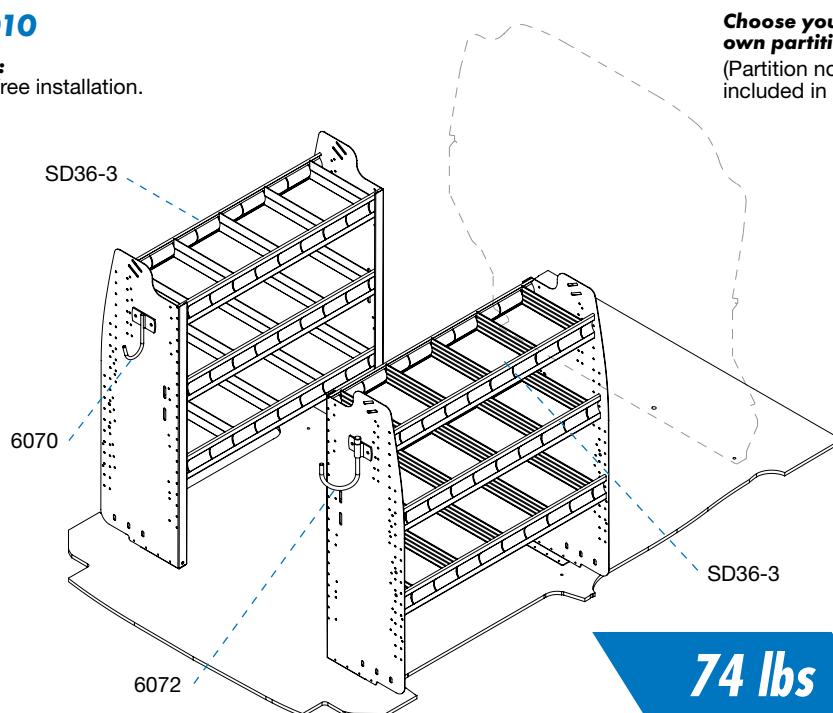

74 lbs

PARTITIONS

Deluxe Steel Contractor Package



Z10-DW

Note:
Drill-free installation.

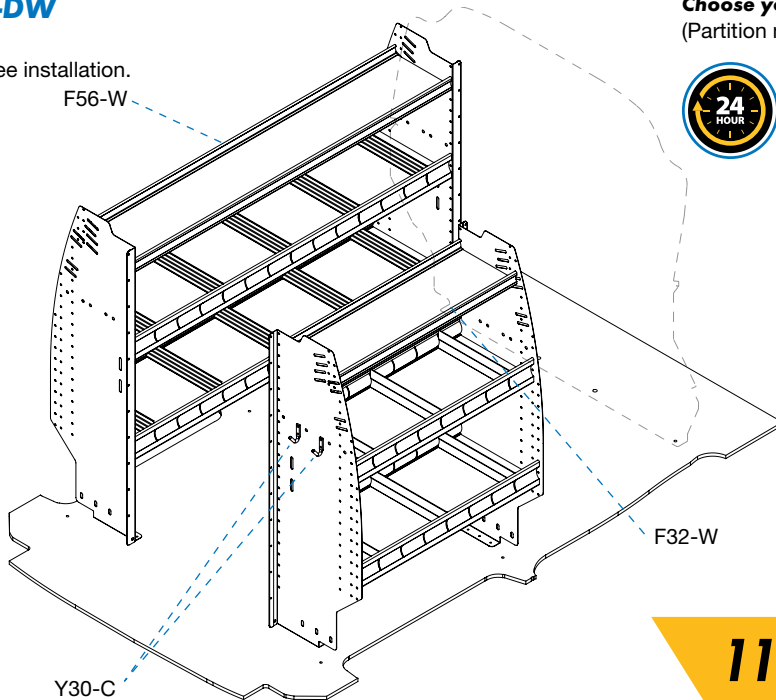

Choose your own partition!
(Partition not included in pkg.)



THESE PACKAGES ARE QUICKSHIP

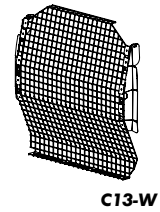
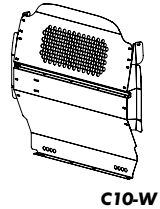
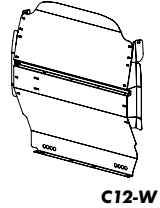

119 lbs

Deluxe Aluminum Contractor Package



W110

Note:
Drill-free installation.

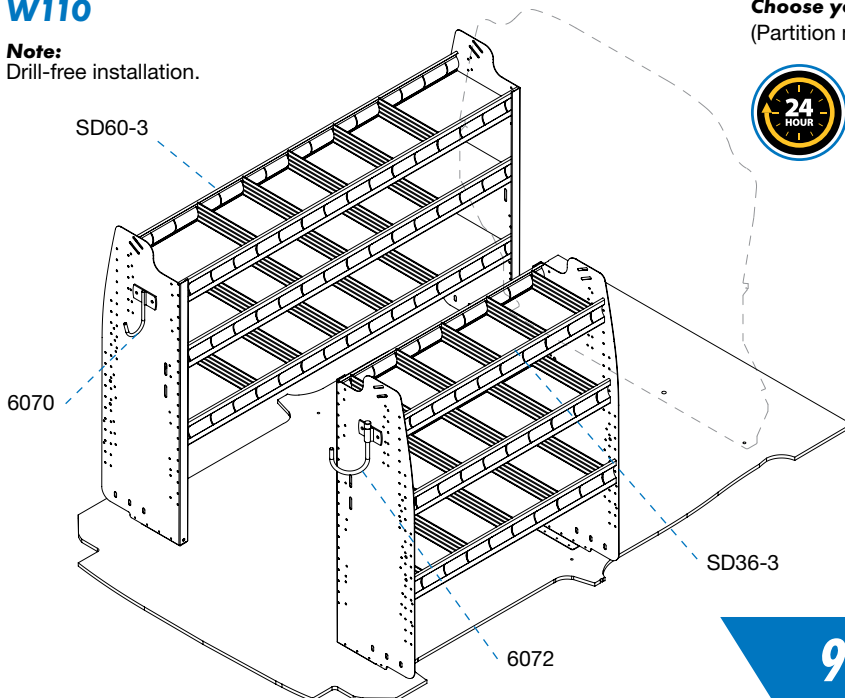

Choose your own partition!
(Partition not included in pkg.)



THESE PACKAGES ARE QUICKSHIP

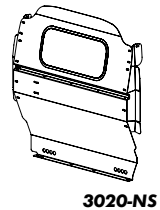
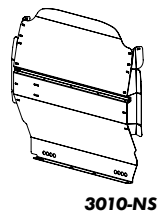

See page 21
for partition details.

90 lbs

See pages 19-20
for package details
and part descriptions.



W116 Deluxe Service Package Shown



SERVICE Packages

Base Steel Service Package

RANGER
FLEETLINE

Z16-BW

Note:
Drill-free installation.

Choose your own partition!
(Partition not included in pkg.)

**TOUGH
JOBS,
TOUGH
TOOLS**

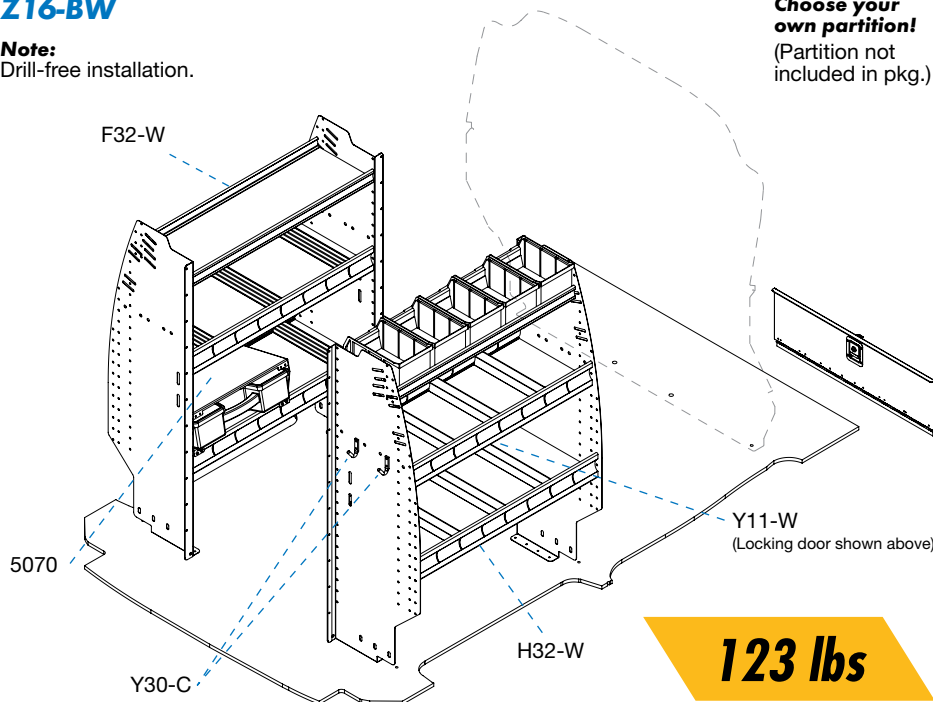

Base Aluminum Service Package

RANGER
PROLINE

W016

Note:
Drill-free installation.

Choose your own partition!
(Partition not included in pkg.)

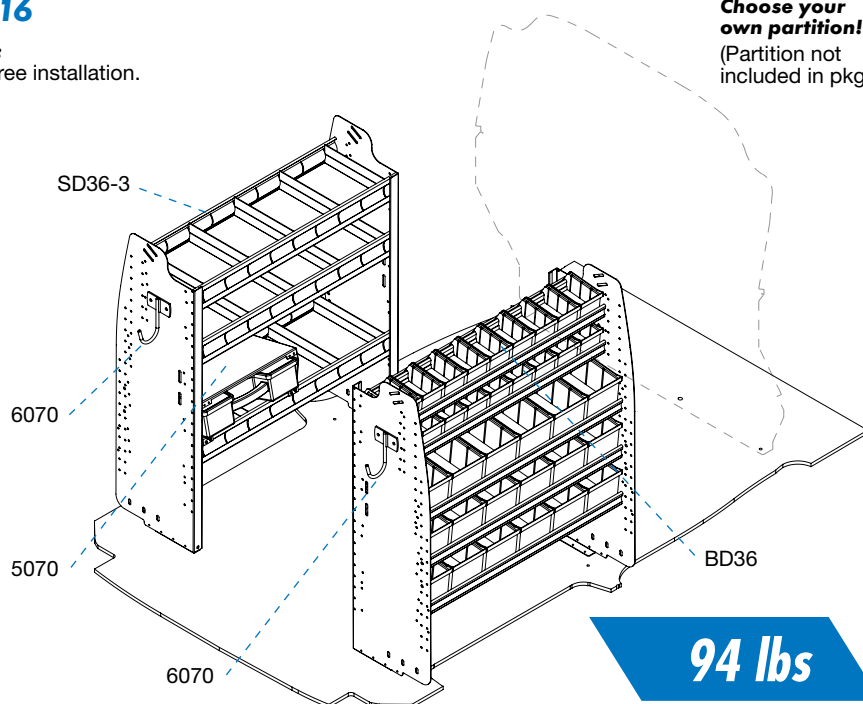

PARTITIONS

Deluxe Steel Service Package



Z16-DW

Note:
Drill-free installation.

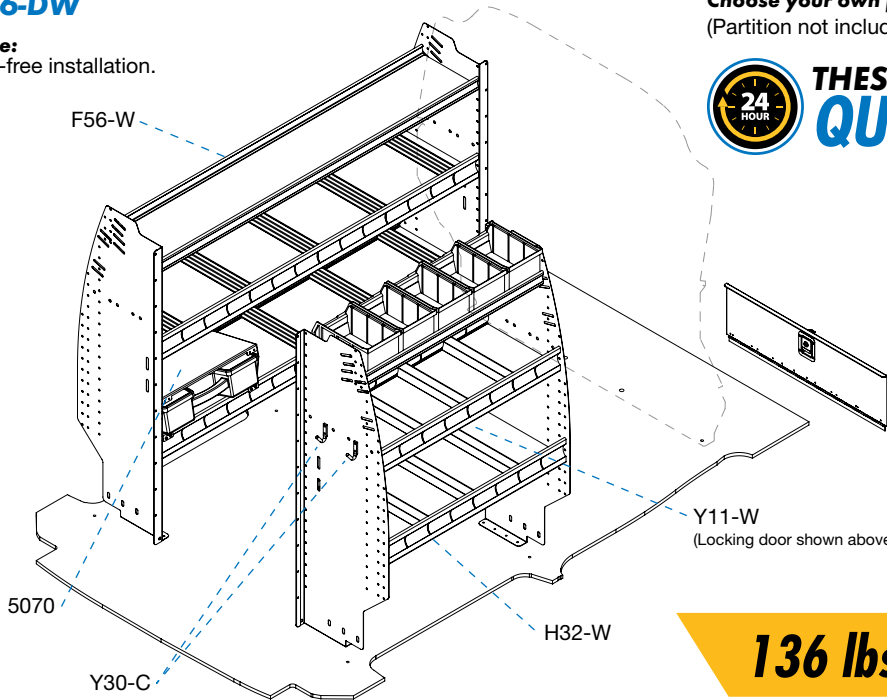

Choose your own partition!
(Partition not included in pkg.)



THESE PACKAGES ARE QUICKSHIP

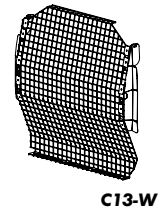
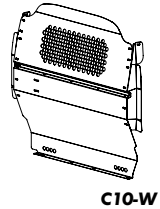
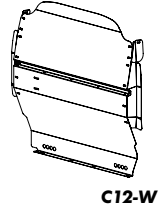

136 lbs

Deluxe Aluminum Service Package



W116

Note:
Drill-free installation.

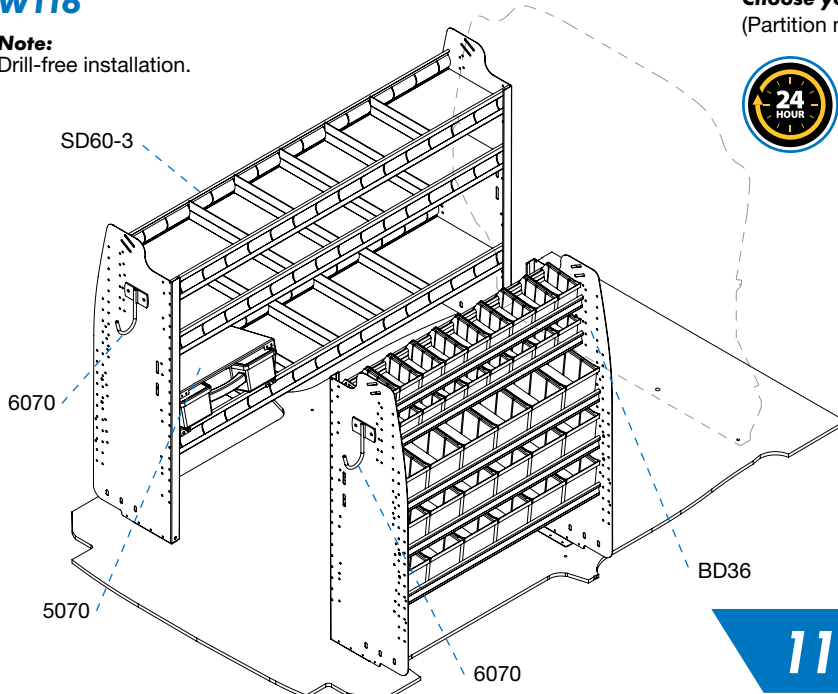

Choose your own partition!
(Partition not included in pkg.)



THESE PACKAGES ARE QUICKSHIP

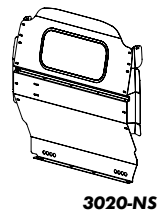
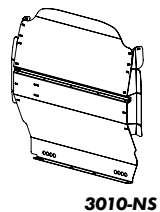

See page 21
for partition details.

110 lbs

See pages 19-20
for package details
and part descriptions.



W111 Deluxe Electrical Package Shown



ELECTRICAL/TELECOM Packages

Base Steel Electrical Package



Z11-BW

Note:
Drill-free installation.

Choose your own partition!
(Partition not included in pkg.)

**TOUGH
JOBS,
TOUGH
TOOLS**

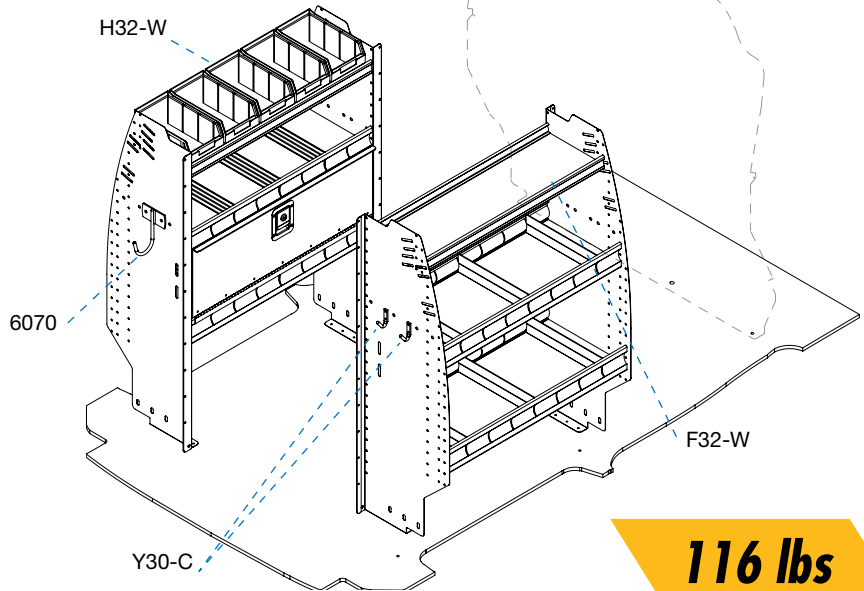

116 lbs

Base Aluminum Electrical Package



W011

Note:
Drill-free installation.

Choose your own partition!
(Partition not included in pkg.)

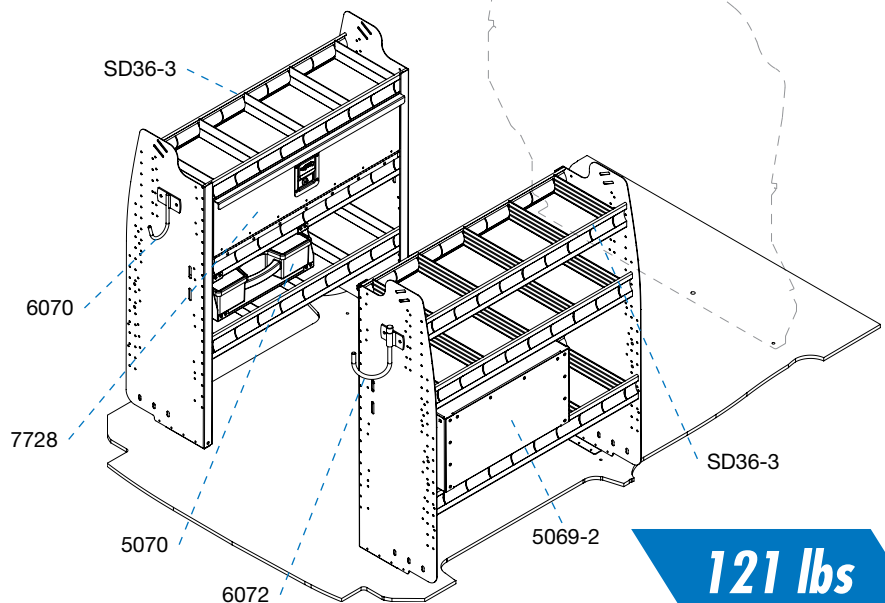

121 lbs

Deluxe Steel Electrical Package



Z11-DW

Note:
Drawer is not a
drill-free installation.

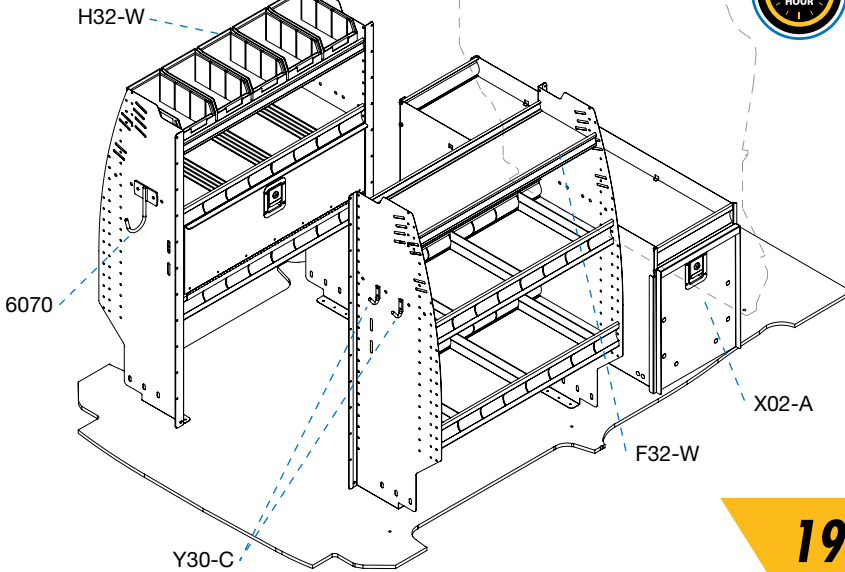

Choose your own partition!
(Partition not included in pkg.)



THESE PACKAGES ARE QUICKSHIP

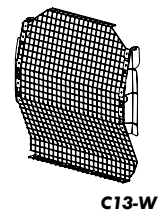
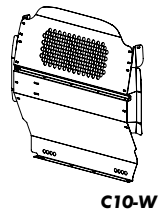
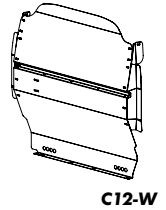

196 lbs

Deluxe Aluminum Electrical Package



W111

Note:
Drawers are not a
drill-free installation.

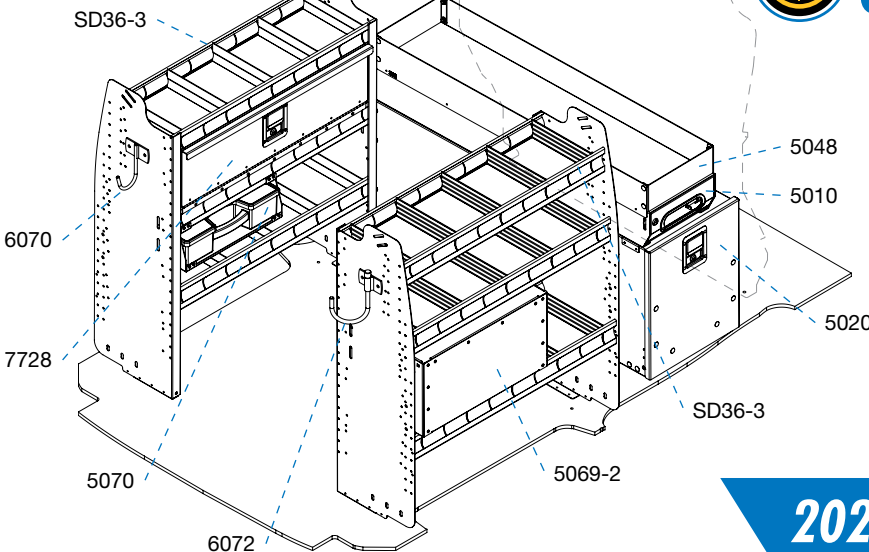

Choose your own partition!
(Partition not included in pkg.)



THESE PACKAGES ARE QUICKSHIP

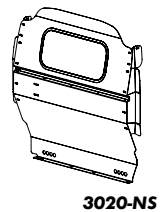
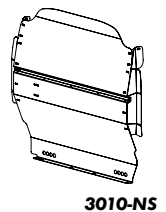

See page 21
for partition details.

202 lbs

See pages 19-20
for package details
and part descriptions.



W019 Base Delivery Package Shown



RANGER
XROSS TRAY

FRAGILE

FRAGILE

DELIVERY Packages

Base Steel Delivery Package



Z19-BW

Note:
Drill-free installation.

Choose your own partition!
(Partition not included in pkg.)

**TOUGH
JOBS,
TOUGH
TOOLS**

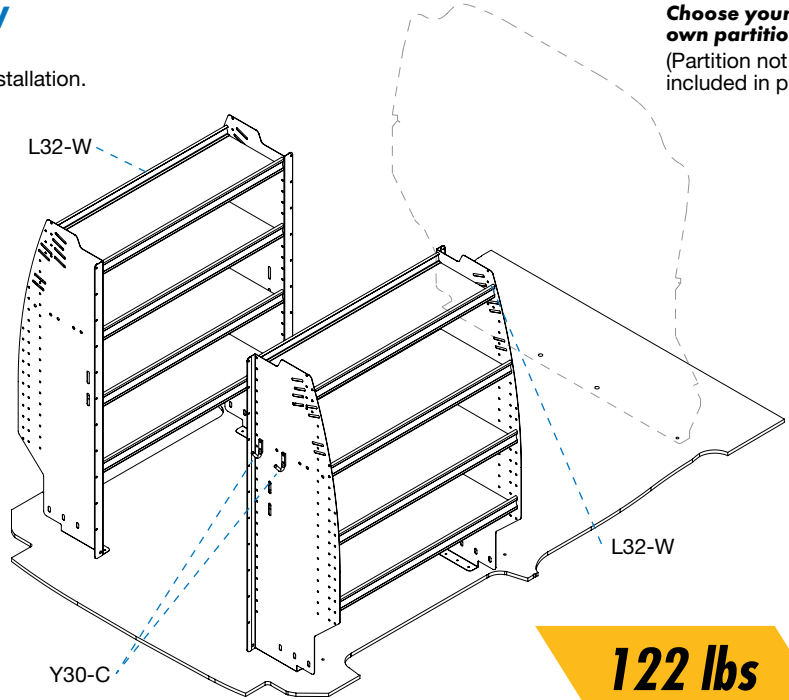

122 lbs

Base Aluminum Delivery Package



W019

Note:
Drill-free installation.

Choose your own partition!
(Partition not included in pkg.)

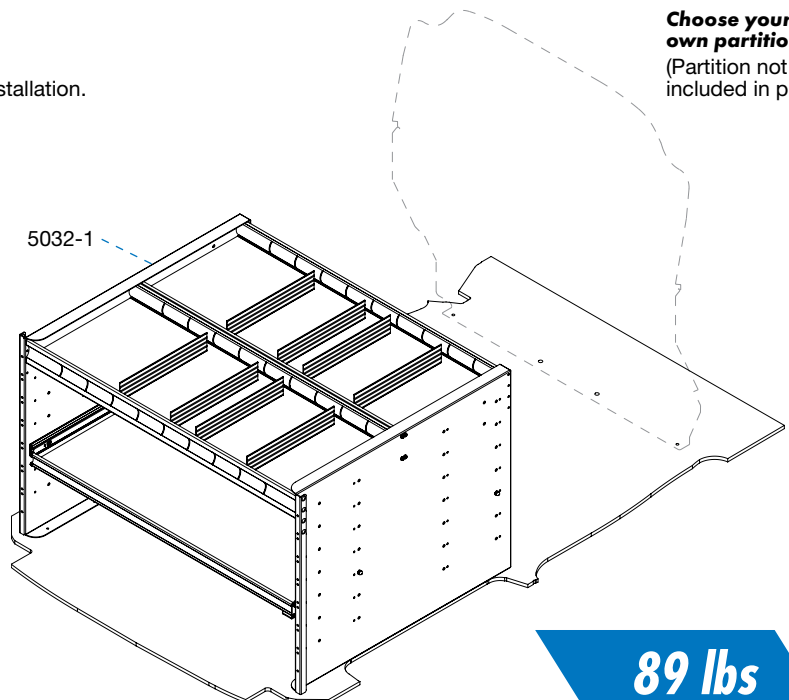

89 lbs



PARTITIONS

Deluxe Steel Delivery Package



Z19-DW

Note:
Drill-free installation.

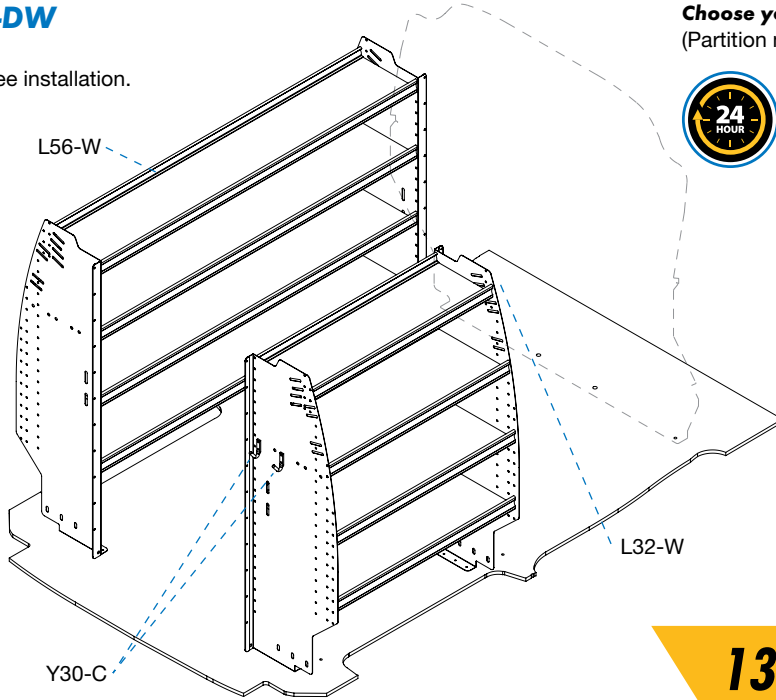

Choose your own partition!
(Partition not included in pkg.)



THESE PACKAGES ARE QUICKSHIP

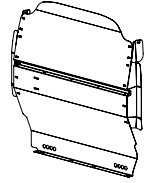

C12-W

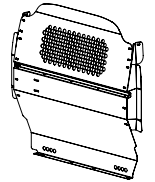

C10-W

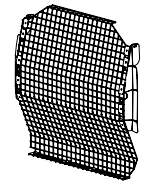

C13-W

139 lbs

Deluxe Aluminum Delivery Package



W119

Note:
Drill-free installation.

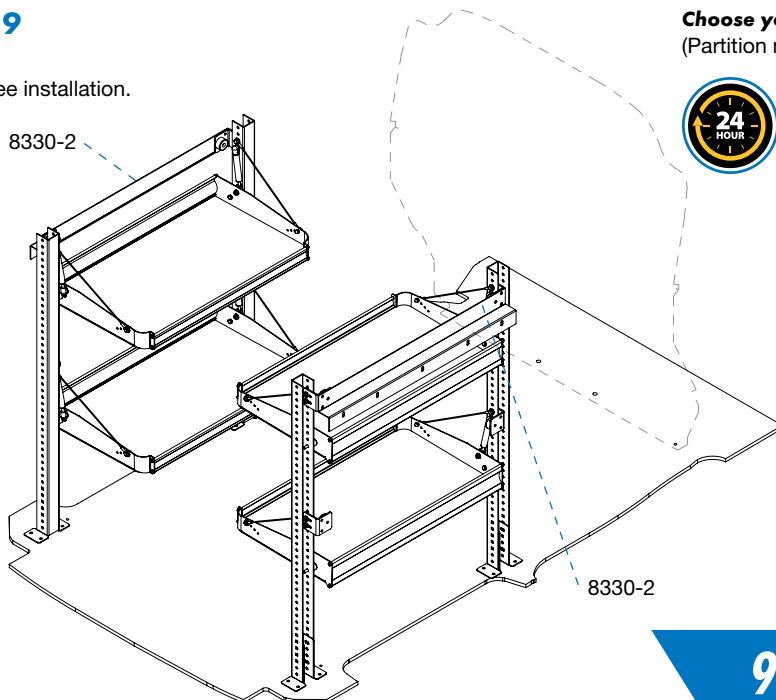

Choose your own partition!
(Partition not included in pkg.)



THESE PACKAGES ARE QUICKSHIP

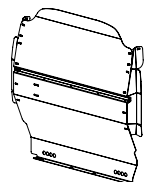

3010-N5

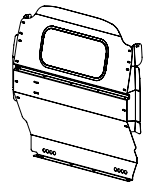

3020-N5

See page 21
for partition details.

90 lbs

See pages 19-20
for package details
and part descriptions.

PARTS INDEX

W010 P 5

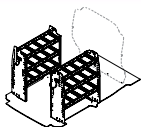

Base Contractor Package (Aluminum) 74 lbs

- 2 **SD36-3** Contoured shelf unit, 3 shelves, 36" W x 40" H
- 1 **6070** 6" Hook, 3" opening
- 1 **6072** 8" Swivel Hook, 4" opening
- 1 **6404** Shelving install track kit, driver side
- 1 **6405** Shelving install track kit, passenger side

W011 P 13

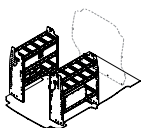

Base Electrical Package (Aluminum) 121 lbs

- 2 **SD36-3** Contoured shelf unit, 3 shelves, 36" W x 40" H
- 1 **6070** 6" Hook, 3" opening
- 1 **6072** 8" Swivel Hook, 4" opening
- 1 **5069-2** 2 Drawer cabinet, 150 lb cap./drawer, 14" D x 24" W x 12" H
- 1 **7728** Locking door, 32 7/8" W x 10 3/8" H
- 1 **5070** Partskeeper carry case w/holder, 14" D x 17" W x 5 1/2" H
- 1 **6404** Shelving install track kit, driver side
- 1 **6405** Shelving install track kit, passenger side

W016 P 9

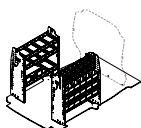

Base Service Package (Aluminum) 94 lbs

- 1 **SD36-3** Contoured shelf unit, 3 shelves, 36" W x 40" H
- 2 **6070** 6" Hook, 3" opening
- 1 **5070** Partskeeper carry case w/holder, 14" D x 17" W x 5 1/2" H
- 1 **BD36** Contoured bin unit, 5 shelves w/bins, 36" W x 40" H
- 1 **6404** Shelving install track kit, driver side
- 1 **6405** Shelving install track kit, passenger side

W019 P 17

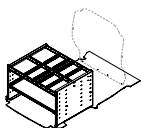

Base Delivery Package (Aluminum) 89 lbs

- 1 **5032-1** Axxess Tray with 1 shelf / 1 drawer, 38" D x 45" W x 30" H
- 1 **6471** Axxess Tray install track kit

W110 P 6

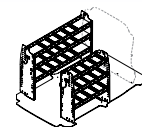

Deluxe Contractor Package (Aluminum) 90 lbs

- 1 **SD60-3** Contoured shelf unit, 3 shelves, 60" W x 40" H
- 1 **6070** 6" Hook, 3" opening
- 1 **6072** 8" Swivel Hook, 4" opening
- 1 **SD36-3** Contoured shelf unit, 3 shelves, 36" W x 40" H
- 1 **6403** Shelving install track kit, driver side
- 1 **6405** Shelving install track kit, passenger side

W111 P 14

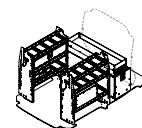

Deluxe Electrical Package (Aluminum) 202 lbs

- 2 **SD36-3** Contoured shelf unit, 3 shelves, 36" W x 40" H
- 1 **6070** 6" Hook, 3" opening
- 1 **6072** 8" Swivel Hook, 4" opening
- 1 **5069-2** 2 Drawer cabinet, 150 lb cap./drawer, 14" D x 24" W x 12" H
- 1 **7728** Locking door, 32 7/8" W x 10 3/8" H
- 1 **5070** Partskeeper carry case w/holder, 14" D x 17" W x 5 1/2" H
- 1 **5020** Tool drawer, 320 lbs capacity, 48" D x 14" W x 16" H
- 1 **5010** Partslider drawer, 150 lbs capacity, 48" D x 12" W x 6" H
- 1 **5048** Top edge, for 5010 Partslider
- 1 **6404** Shelving install track kit, driver side
- 1 **6405** Shelving install track kit, passenger side

W116 P 10

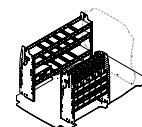

Deluxe Service Package (Aluminum) 110 lbs

- 1 **SD60-3** Contoured shelf unit, 3 shelves, 60" W x 40" H
- 2 **6070** 6" Hook, 3" opening
- 1 **5070** Partskeeper carry case w/holder, 14" D x 17" W x 5 1/2" H
- 1 **BD36** Contoured bin unit, 5 shelves w/bins, 36" W x 40" H
- 1 **6403** Shelving install track kit, driver side
- 1 **6405** Shelving install track kit, passenger side

W119 P 18

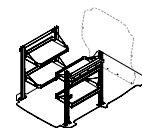

Deluxe Delivery Package (Aluminum) 90 lbs

- 2 **8330-2** Fold-Away shelving unit, 2 levels, 18" D x 37" W x 46 1/2" H
- 1 **84-7107** Fold-Away shelving install kit, driver side
- 1 **84-7108** Fold-Away shelving install kit, passenger side

PARTS INDEX

Z10-BW P 5

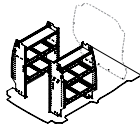

Base Contractor Package (Steel) 106 lbs

2	F32-W	Contoured shelving unit, 1 open & 2 divided shelves, 32" W
2	Y30-C	Coat Hook, 1" opening
1	6410	Shelving install track kit, 32" L units, passenger side
1	6411	Shelving install track kit, 32" L units, driver side

Z11-BW P 13

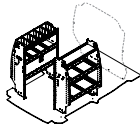

Base Electrical Package (Steel) 116 lbs

1	H32-W	Contoured shelving unit, 1 bin & 2 divided shelves & a door, 32" W
1	F32-W	Contoured shelving unit, 1 open & 2 divided shelves, 32" W
1	6070	6" Hook, 3" opening
2	Y30-C	Coat Hook, 1" opening
1	6410	Shelving install track kit, 32" L units, passenger side
1	6411	Shelving install track kit, 32" L units, driver side

Z16-BW P 9

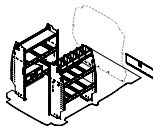

Base Service Package (Steel) 123 lbs

1	F32-W	Contoured shelving unit, 1 open & 2 divided shelves, 32" W
1	H32-W	Contoured shelving unit, 1 bin & 2 divided shelves & a door, 32" W
2	Y30-C	Coat Hook, 1" opening
1	5070	Partskeeper carry case w/holder, 14" D x 17" W x 5½" H
1	6410	Shelving install track kit, 32" L units, passenger side
1	6411	Shelving install track kit, 32" L units, driver side

Z19-BW P 17

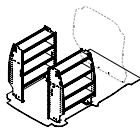

Base Delivery Package (Steel) 122 lbs

2	L32-W	Contoured shelving unit, 4 open shelves, 32" W
2	Y30-C	Coat Hook, 1" opening
1	6410	Shelving install track kit, 32" L units, passenger side
1	6411	Shelving install track kit, 32" L units, driver side

Z10-DW P 6

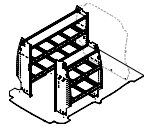

Deluxe Contractor Package (Steel) 119 lbs

1	F56-W	Contoured shelving unit, 1 open & 2 divided shelves, 56" W
1	F32-W	Contoured shelving unit, 1 open & 2 divided shelves, 32" W
2	Y30-C	Coat Hook, 1" opening
1	6406	Shelving install track kit, driver side
1	6410	Shelving install track kit, 32" L units, passenger side

Z11-DW P 14

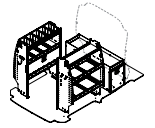

Deluxe Electrical Package (Steel) 196 lbs

1	H32-W	Contoured shelving unit, 1 bin & 2 divided shelves & a door, 32" W
1	F32-W	Contoured shelving unit, 1 open & 2 divided shelves, 32" W
1	6070	6" Hook, 3" opening
2	Y30-C	Coat Hook, 1" opening
1	X02-A	Fleetline Tool Drawer, 45½" D x 13½" W x 22" H
1	6410	Shelving install track kit, 32" L units, passenger side
1	6411	Shelving install track kit, 32" L units, driver side

Z16-DW P 10

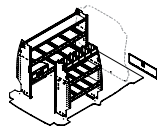

Deluxe Service Package (Steel) 136 lbs

1	F56-W	Contoured shelving unit, 1 open & 2 divided shelves, 56" W
1	H32-W	Contoured shelving unit, 1 bin & 2 divided shelves & a door, 32" W
2	Y30-C	Coat Hook, 1" opening
1	5070	Partskeeper carry case w/holder, 14" D x 17" W x 5½" H
1	6406	Shelving install track kit, driver side
1	6410	Shelving install track kit, 32" L units, passenger side



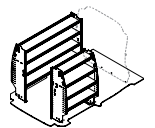

Z19-DW P 18



Deluxe Delivery Package (Steel) 139 lbs

1	L56-W	Contoured shelving unit, 4 open shelves, 56" W
1	L32-W	Contoured shelving unit, 4 open shelves, 32" W
2	Y30-C	Coat Hook, 1" opening
1	6406	Shelving install track kit, driver side
1	6410	Shelving install track kit, 32" L units, passenger side



ADDITIONAL PRODUCTS

 : Weight Capacity  : Install Time  : Weight  : Dimensions

Choose your partition!

C10-W

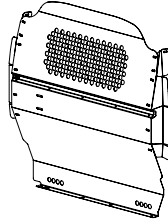

Contoured Safety Partition, Steel, with perforated window

 : 1  : 53 lbs



C12-W

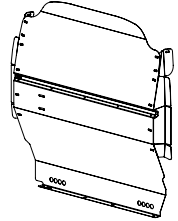

Contoured Safety Partition, Steel

 : 1  : 53 lbs



C13-W

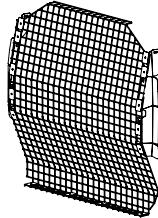

Contoured Wire Mesh Safety Partition, Steel

 : 0.7  : 27 lbs



3010-NS

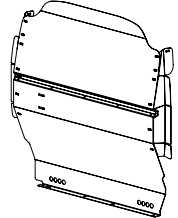

Contoured safety partition, Aluminum

 : 1  : 42 lbs



3020-NS

Contoured Partition, Aluminum Tempered Glass Window

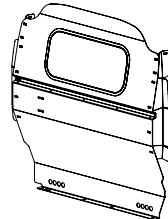

 : 1  : 42 lbs



Choose your ladder rack!

1505-NS

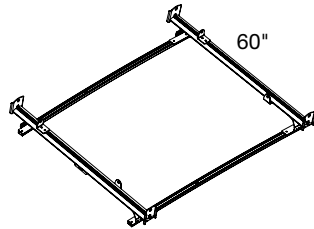

Cargo Rack, Aluminum, 2 bar

 : 480 lbs  : 0.8
 : 18 lbs



1510-NS

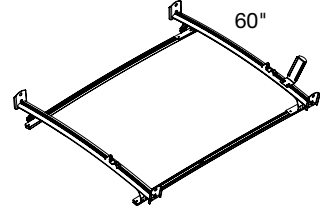

Standard Ladder Rack, Aluminum, 2 bar

 : 400 lbs  : 0.9
 : 18 lbs



1520-NS

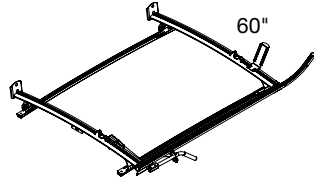

Single Clamp Ladder Rack, Aluminum, 2 bar

 : 400 lbs  : 1.2
 : 28 lbs



1525-NS

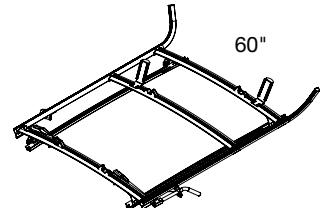

Combination Ladder Rack, Aluminum, 2 bar

 : 400 lbs  : 1.7
 : 43 lbs



1530-NS

Double Clamp Ladder Rack, Aluminum, 2 bar



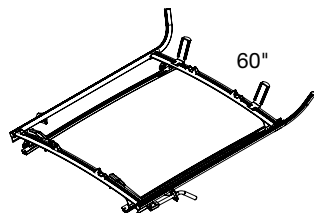

 : 400 lbs  : 1.7
 : 36 lbs



ADDITIONAL PRODUCTS





5010

Partslider Drawer, Aluminum

 : 48" D x 12" W x 6" H
 : 150 lbs  : 0.5
 : 30 lbs



5020

Tool Drawer, Aluminum

 : 48" D x 14" W x 16" H
 : 320 lbs  : 1.0
 : 46 lbs

5048

Top Edge, Aluminum, for 5010 Partslider

 : 48" D x 12" W x 4" H
 : 0.2  : 5 lbs

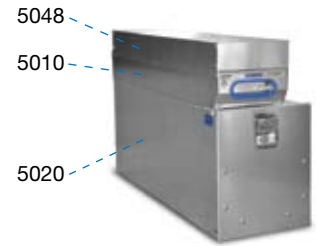

5070

Partskeeper carry case with aluminum holder, Universal Mount

 : 14" D x 17" W x 5½" H
 : 0.5  : 7 lbs

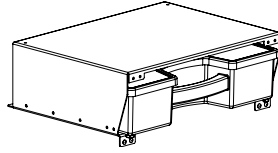

6040

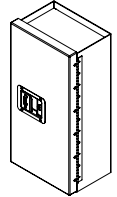

Locking Cabinet, Aluminum

 : 8.5" D x 12" W x 24" H
 : 0.6  : 16 lbs



6041

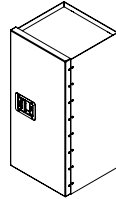

Locking Cabinet, Aluminum

 : 15" D x 15½" W x 33" H
 : 0.7  : 26 lbs



6061

2-Slot Paper Holder, Aluminum, Deep

 : 3¾" D x 12¾" W x 12" H
 : 0.2  : 2 lbs

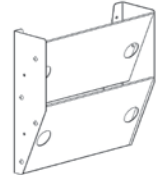

6070

6" Hook, Powder Coated Aluminum, 3" Opening

 : 0.2  : 1 lb



6072



8" Swivel Hook, Powder Coated Aluminum, 4" Opening

 : 0.2  : 1 lb





6086

Small Aluminum Bottle Holder (Comes with a 36" blue nylon strap)

 : 6" W x 12" H
 : 0.2  : 1 lb

6088



Large Aluminum Bottle Holder (Comes with two 36" blue nylon straps)

 : 8" W x 24" H
 : 0.2  : 2 lbs



Y31-A

3-Slot Paper Holder, Steel, Deep

 : 3¾" D x 12¾" W x 16" H
 : 0.2  : 9 lbs

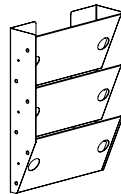

Y35-B

Medium Bin

 : 10" D x 6" W x 4½" H

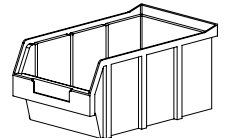

Y35-D

Large Bin

 : 14" D x 8" W x 5½" H

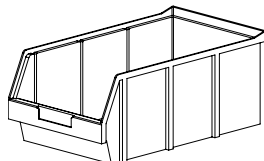

Nissan NV200 Layout Guide

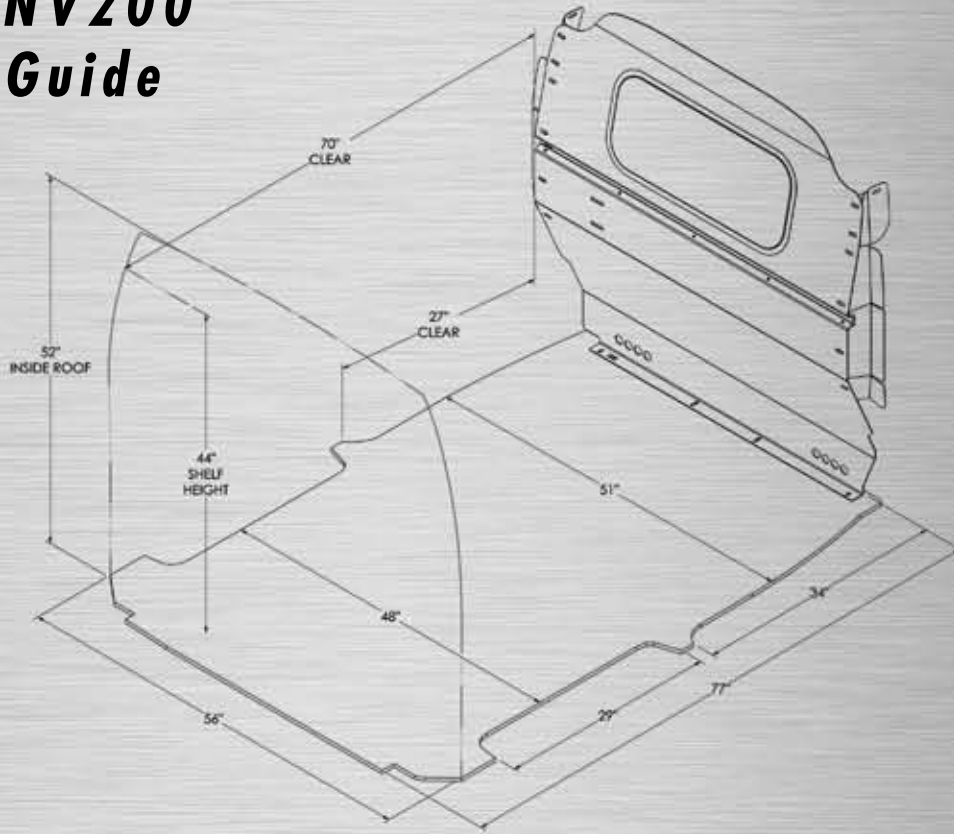

RANGER
DESIGN

Customer Service
cs@rangerdesigninc.com
(800) 565-5321
www.rangerdesign.com
info@rangerdesign.com



Your Local Dealer:

M110-124