

Equipment for Commercial Vehicles



Chevrolet City Express UPFIT GUIDE



ASK YOUR LOCAL
DISTRIBUTOR ABOUT
**RANGER
QUICKSHIP**



1 (800) 565-5321 // www.rangerdesign.com

RANGER
DESIGN



“Ranger combines old-fashioned service with state of the art technology...”

In 1988, with a passion for innovation and service, Ranger began to build equipment for commercial vehicles.

Now with locations in Rochester, NY, San Francisco, CA and Montreal, Canada, and a strong network of dealers across North America, Ranger Design services all trades and the same values still drive the company today.

In our modern fast-paced world, Ranger combines old-fashioned service with state of the art technology

to bring you consistent quality and strength to meet the toughest demands. This is why more Tradesmen and Fleets across the nation are turning to Ranger solutions for shelving units, storage systems, partitions and ladder racks to address their unique needs.

CONTACT US TODAY AND EXPERIENCE THE RANGER DIFFERENCE FOR YOURSELF!

// ROCHESTER, NY
MANUFACTURING PLANT



// SAN FRANCISCO, CA
SALES OFFICE



// MONTREAL, CANADA
MANUFACTURING PLANT



RANGER HAS OVER
300
DISTRIBUTERS
ACROSS THE CONTINENT

RANGER'S MISSION

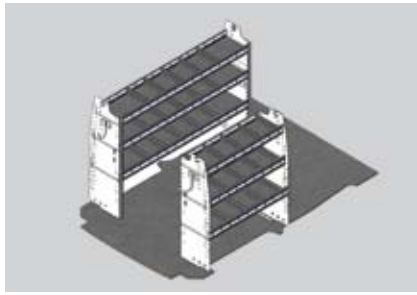
“HELPING MOBILE TECHNICIANS WORK MORE EFFECTIVELY BY PROVIDING ORGANIZED STORAGE SOLUTIONS”

VISIT
**RANGERDESIGN.COM/
FIND-DEALER/**
TO FIND A DEALER
NEAR YOU!

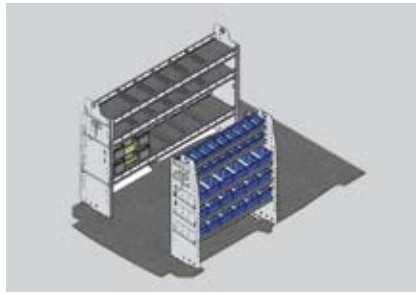


TABLE OF CONTENTS

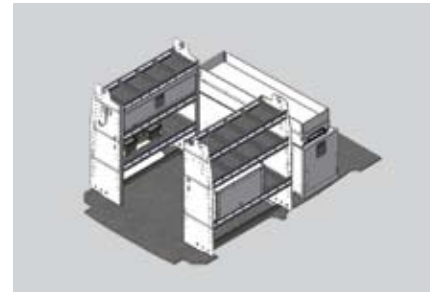
PACKAGES



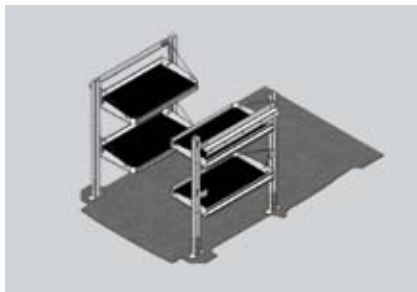
// Contractor 3-6



// Service 7-10



// Electrical 11-14



// Delivery 15-18



// Parts Index 19-20



// Accessories 21-22

QUICKSHIP

RANGER DESIGN
PROVIDES THE
POWER OF
**24-HOUR
SHIPPING**

To get you on the road to success faster than ever! Ranger **Quickship** guarantees that all packages ordered with the **Quickship** service will ship within 24 hours if ordered before 1PM EST. Visit our website www.rangerquickship.com for ordering details or contact one of our Customer Service representatives at cs@rangerdesigninc.com or call Toll-Free at 1 (800) 565-5321.



We are pleased to offer efficient, personalized service. At Ranger you can be sure of speaking to one of our professionals every time you call. Our dedicated team of friendly representatives is always ready to help you out with any questions or requests you may have!

TOUGH

**CRASH
TESTED**



QUIET

A PEACEFUL
RIDE WITH
**NO
RATTLES**



PAYLOAD

ENGINEERED
TO
**SAVE
WEIGHT**





// W010

**BASE CONTRACTOR
PACKAGE**



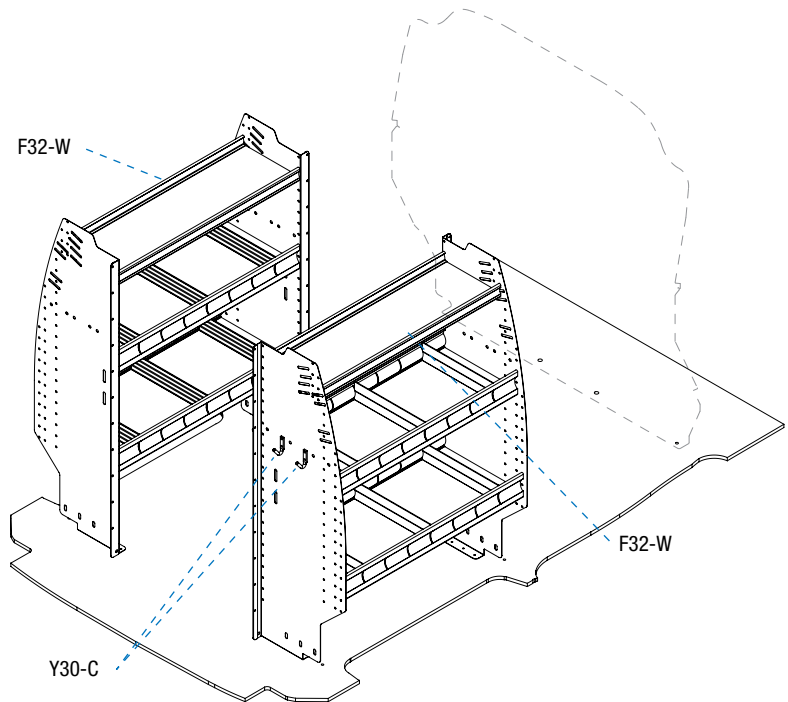
CONTRACTOR PACKAGES



Base Steel Contractor Package - Z10-BW



- // 106 lbs
- // Drill-free installation
- // Choose your partition!
(Partition not included in pkg.)



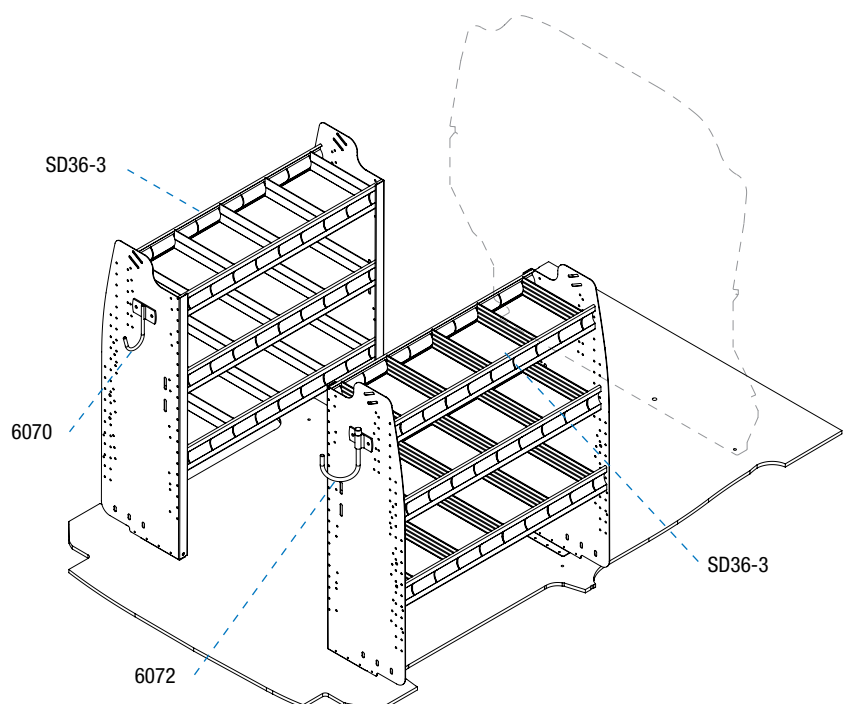
Base Aluminum Contractor Package - W010



- // 74 lbs
- // Drill-free installation
- // Choose your partition!
(Partition not included in pkg.)



W010 Package shown with a 3020-NS window partition.

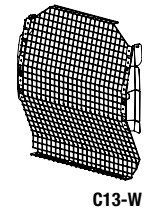
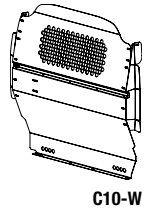
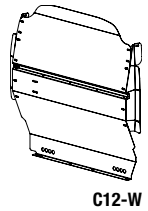
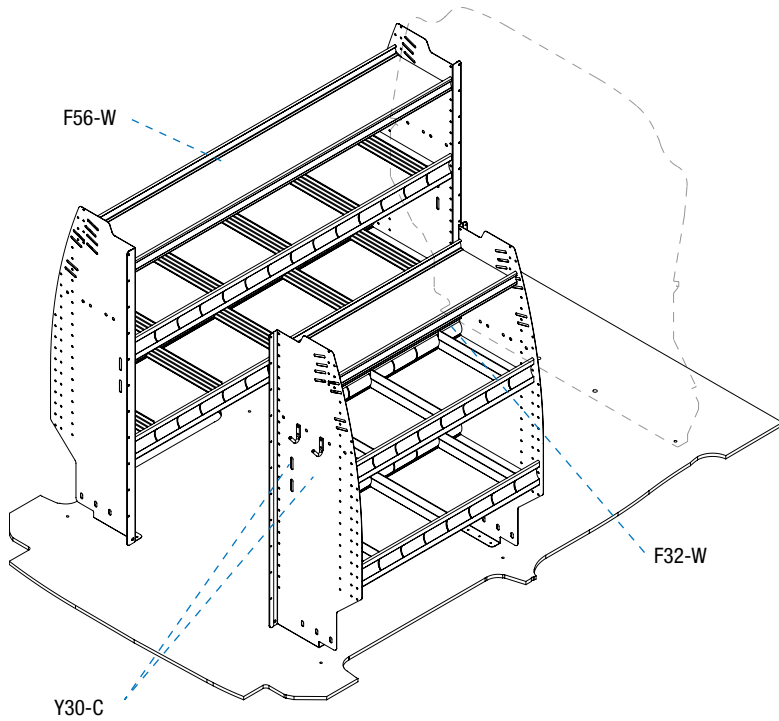




Deluxe Steel Contractor Package - Z10-DW



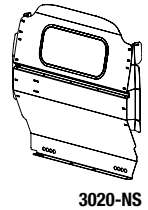
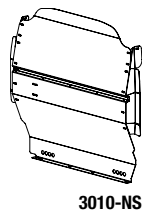
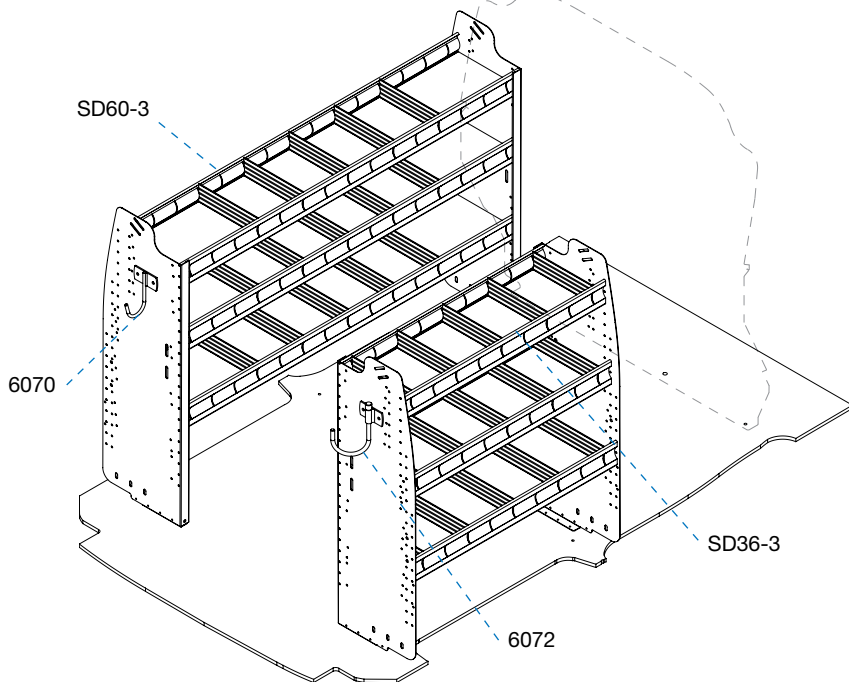
- // 119 lbs
- // Drill-free installation
- // Choose your partition!
(Partition not included in pkg.)



Deluxe Aluminum Contractor Package - W110



- // 90 lbs
- // Drill-free installation
- // Choose your partition!
(Partition not included in pkg.)



See pages 19-20
for package details
and part descriptions.

See page 21
for partition details.



// W116
DELUXE SERVICE
PACKAGE



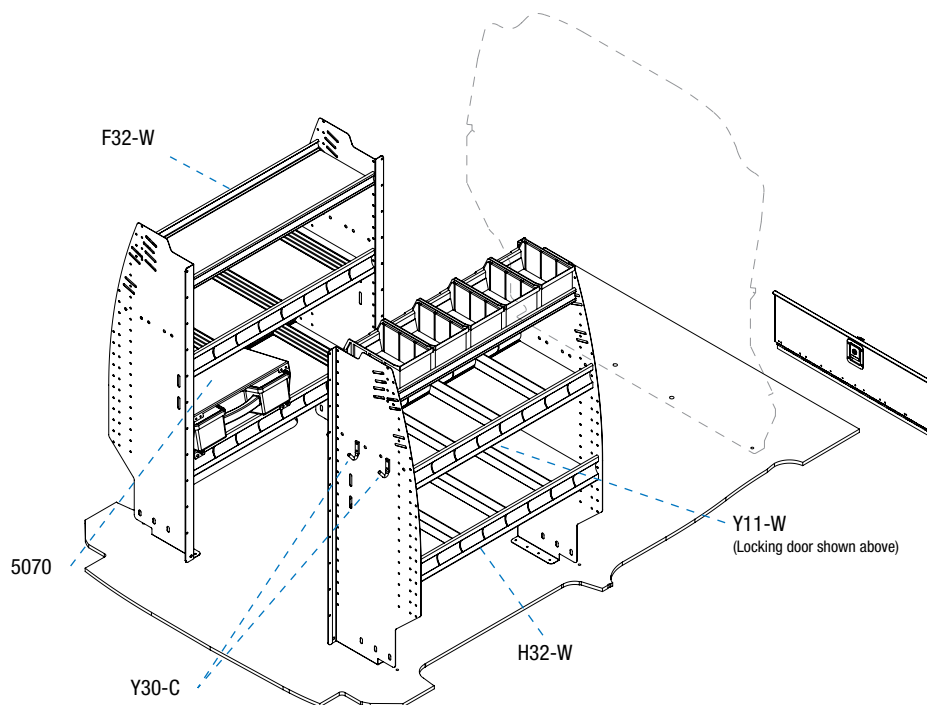
SERVICE PACKAGES



Base Steel Service Package - Z16-BW



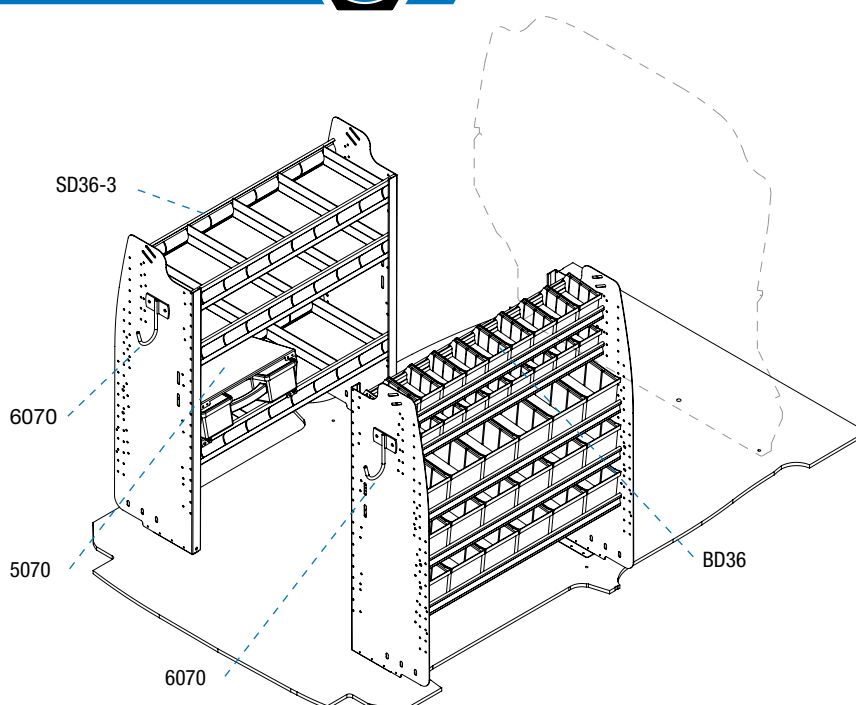
- // 123 lbs
- // Drill-free installation
- // Choose your partition!
(Partition not included in pkg.)



Base Aluminum Service Package - W016



- // 94 lbs
- // Drill-free installation
- // Choose your partition!
(Partition not included in pkg.)

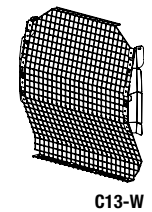
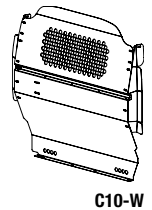
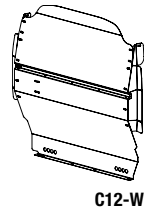
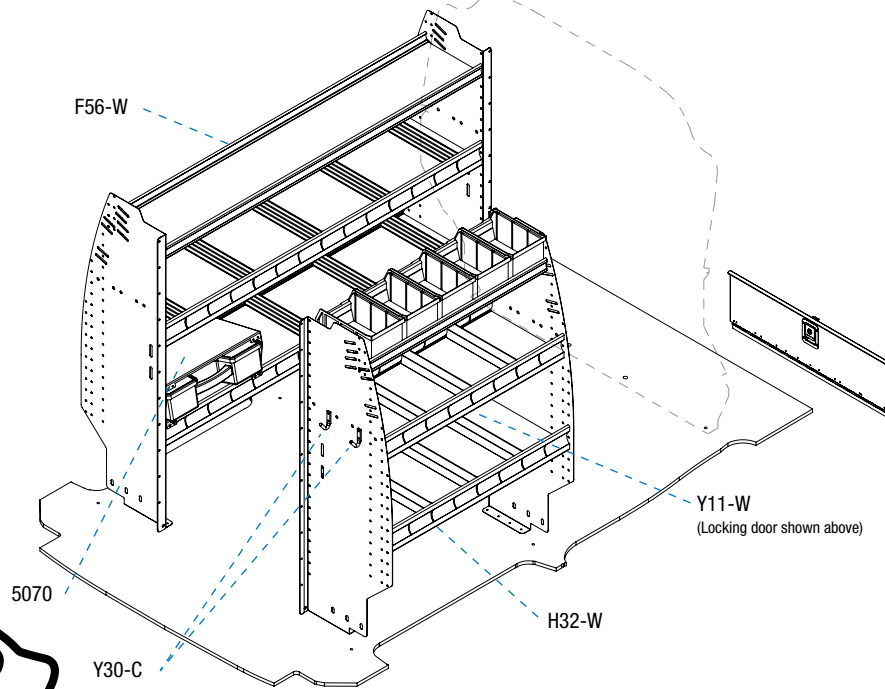




Deluxe Steel Service Package - Z16-DW



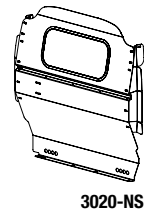
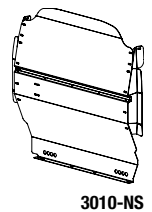
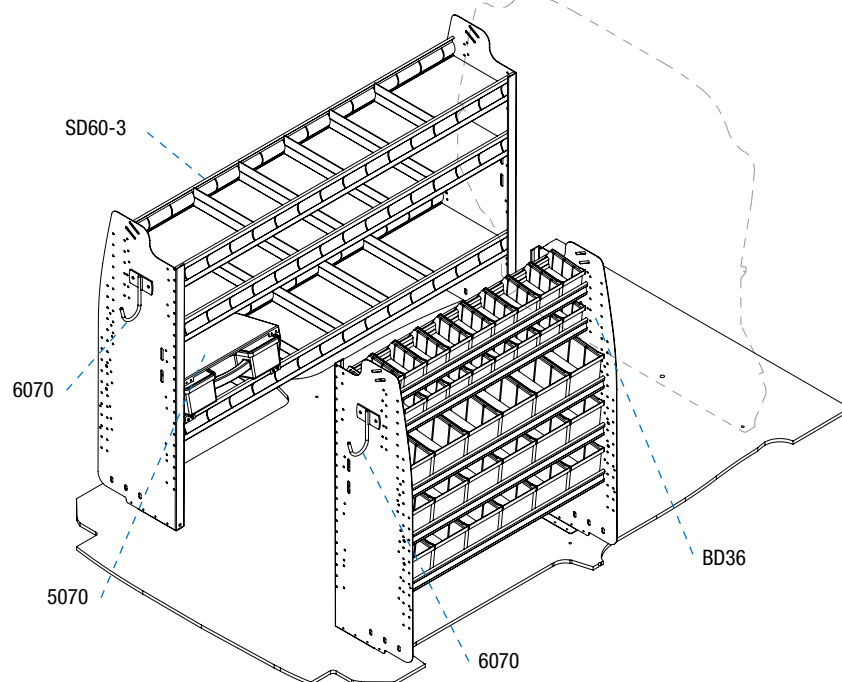
- // 136 lbs
- // Drill-free installation
- // Choose your partition!
(Partition not included in pkg.)



Deluxe Aluminum Service Package - W116



- // 110 lbs
- // Drill-free installation
- // Choose your partition!
(Partition not included in pkg.)



See pages 19-20
for package details
and part descriptions.

See page 21
for partition details.



// W111

**DELUXE
ELECTRICAL PACKAGE**



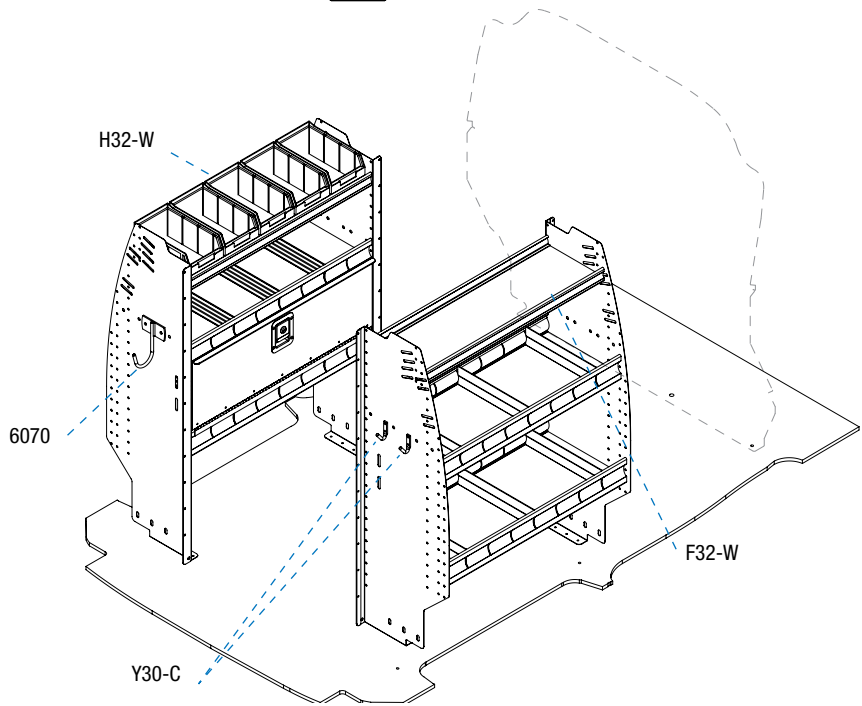
ELECTRICAL / TELECOM PACKAGES



Base Steel Electrical Package - Z11 - BW



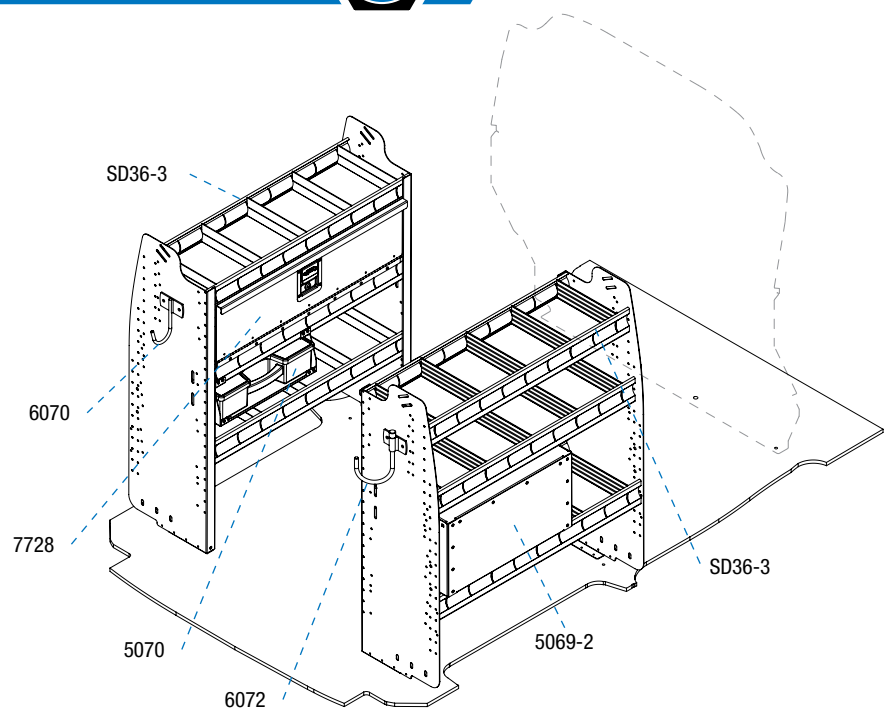
- // 116 lbs
- // Drill-free installation
- // Choose your partition!
(Partition not included in pkg.)



Base Aluminum Electrical Package - W011



- // 121 lbs
- // Drill-free installation
- // Choose your partition!
(Partition not included in pkg.)

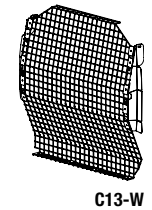
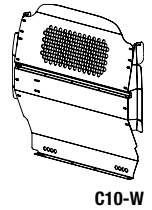
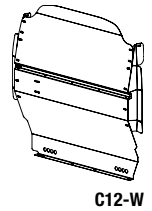
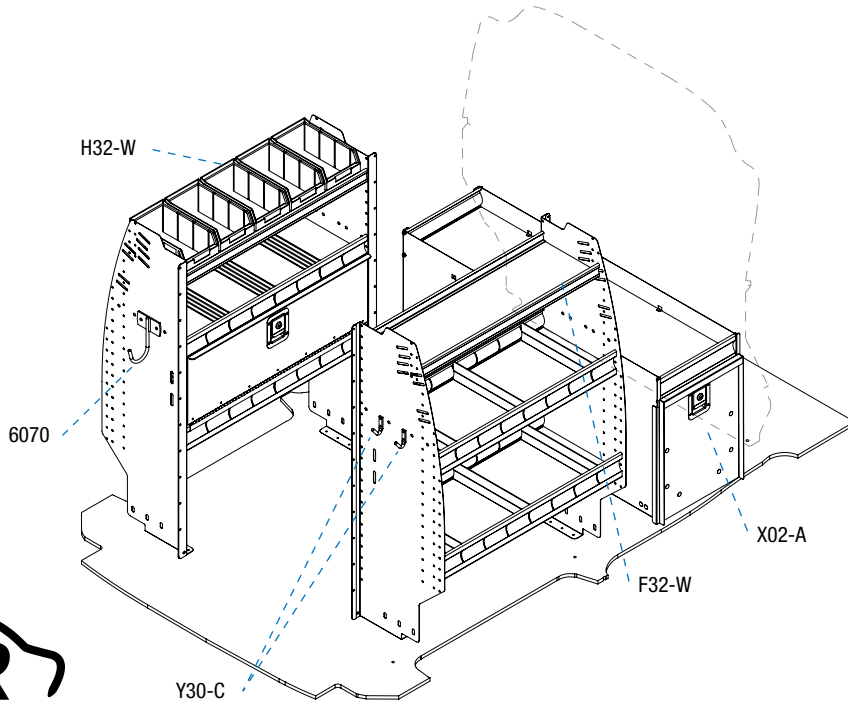




Deluxe Steel Electrical Package - Z11 - DW



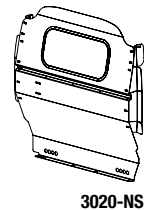
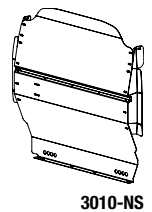
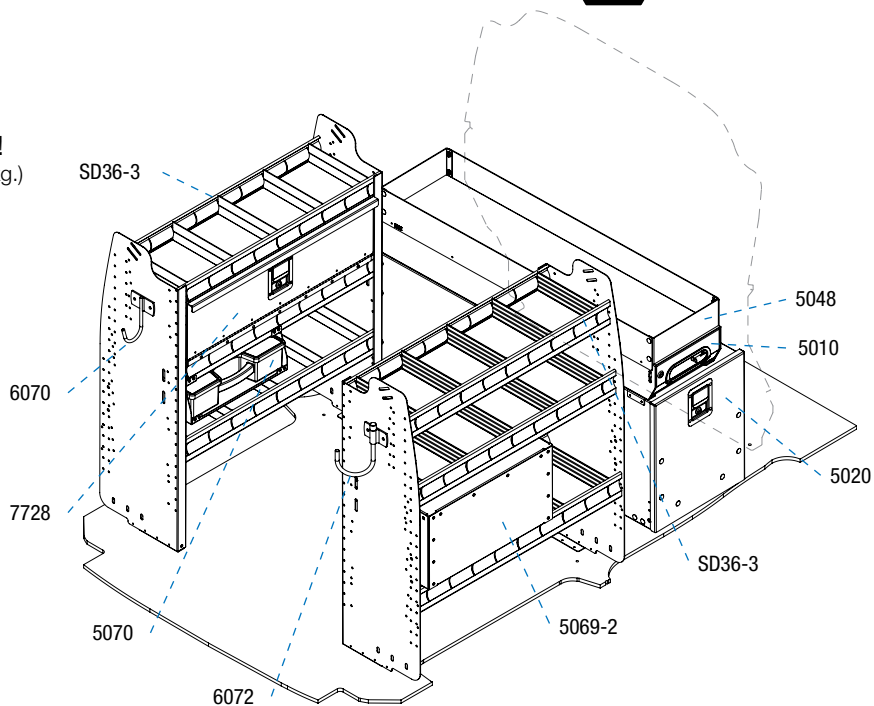
- // 196 lbs
- // Drill-free installation
- // Choose your partition!
(Partition not included in pkg.)



Deluxe Aluminum Electrical Package - W111



- // 202 lbs
- // Drill-free installation
- // Choose your partition!
(Partition not included in pkg.)



See pages 19-20
for package details
and part descriptions.

See page 21
for partition details.





// W019
BASE DELIVERY
PACKAGE

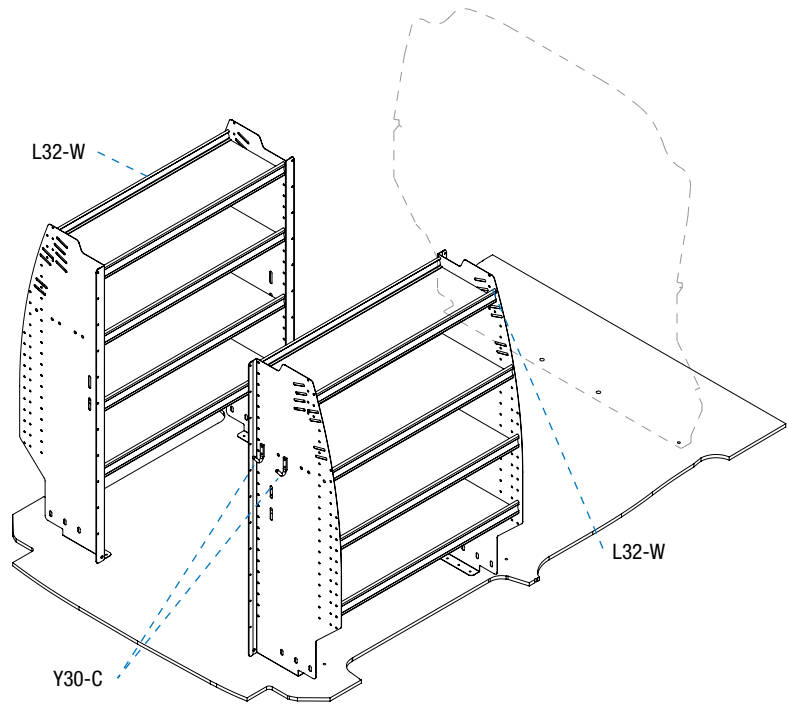
DELIVERY PACKAGES



Base Steel Delivery Package - Z19-BW



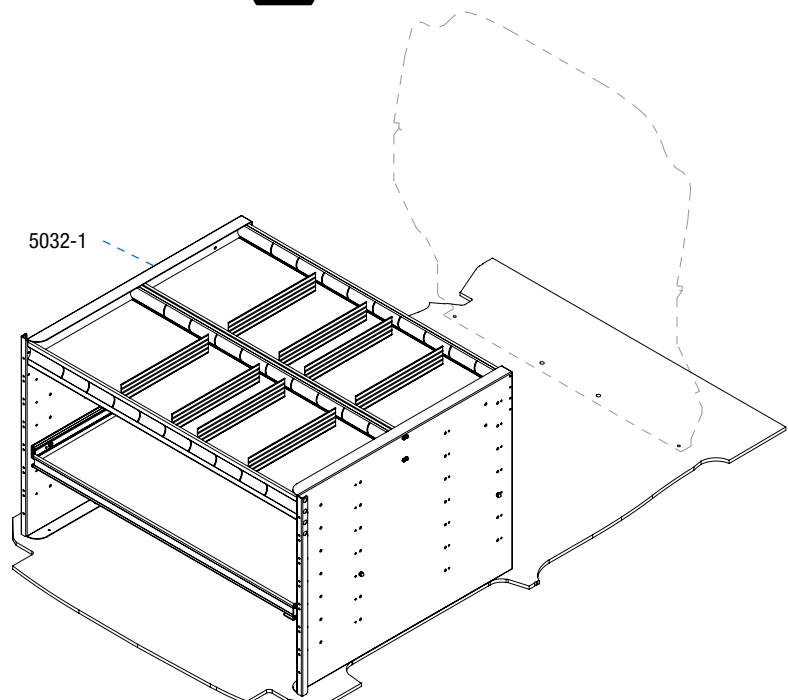
- // 122 lbs
- // Drill-free installation
- // Choose your partition!
(Partition not included in pkg.)



Base Aluminum Delivery Package - W019



- // 89 lbs
- // Drill-free installation
- // Choose your partition!
(Partition not included in pkg.)

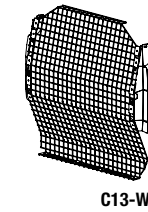
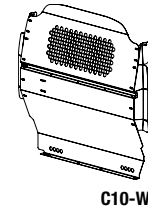
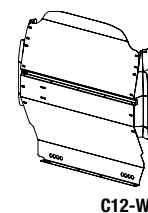
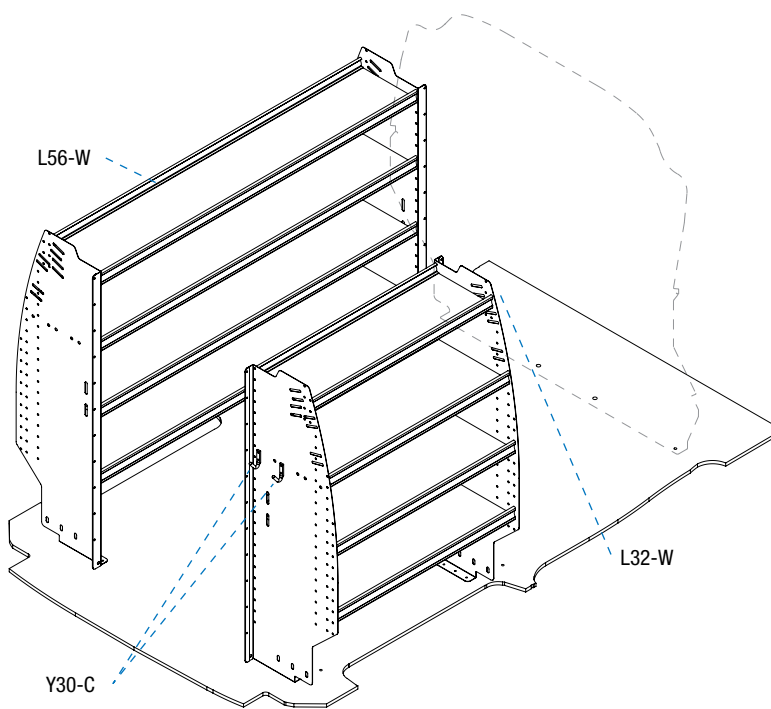




Deluxe Steel Delivery Package - Z19-DW



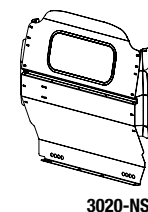
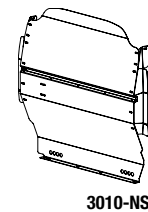
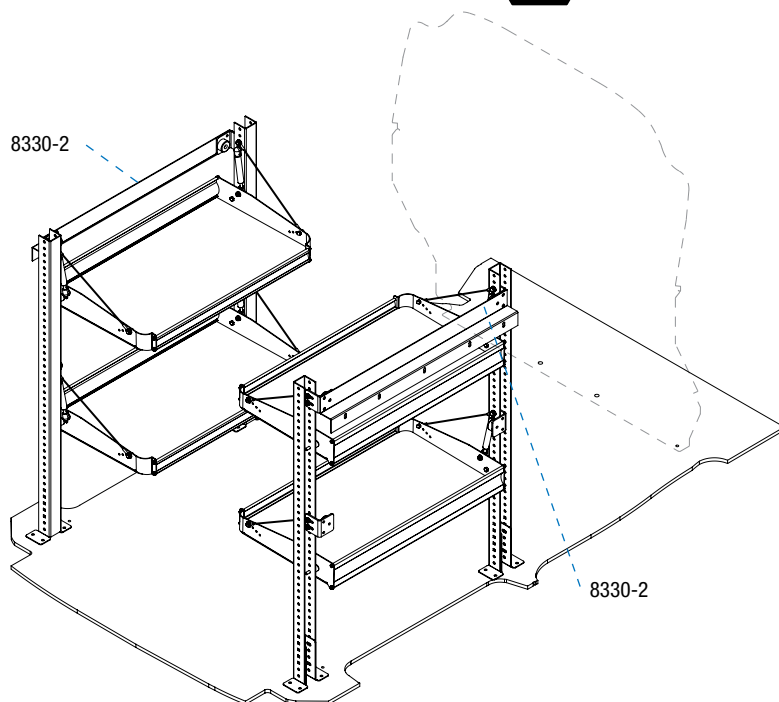
- // 139 lbs
- // Drill-free installation
- // Choose your partition!
(Partition not included in pkg.)



Deluxe Aluminum Delivery Package - W119



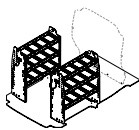
- // 90 lbs
- // Drill-free installation
- // Choose your partition!
(Partition not included in pkg.)



See pages 19-20
for package details
and part descriptions.

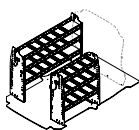
See page 21
for partition details.

W010 P 5 BASE CONTRACTOR PACKAGE ALUMINUM 74 lbs



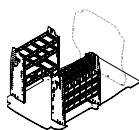
2	SD36-3	Contoured shelf unit, 3 shelves, 36" W x 40" H
1	6070	6" Hook, 3" opening
1	6072	8" Swivel Hook, 4" opening
1	6404	Shelving install track kit, driver side
1	6405	Shelving install track kit, passenger side

W110 P 6 DELUXE CONTRACTOR PACKAGE ALUMINUM 90 lbs



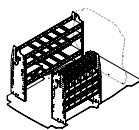
1	SD60-3	Contoured shelf unit, 3 shelves, 60" W x 40" H
1	SD36-3	Contoured shelf unit, 3 shelves, 36" W x 40" H
1	6070	6" Hook, 3" opening
1	6072	8" Swivel Hook, 4" opening
1	6403	Shelving install track kit, driver side
1	6405	Shelving install track kit, passenger side

W016 P 9 BASE SERVICE PACKAGE ALUMINUM 94 lbs



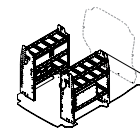
1	SD36-3	Contoured shelf unit, 3 shelves, 36" W x 40" H
2	6070	6" Hook, 3" opening
1	5070	Partskeeper carry case w/holder, 14" D x 17" W x 5½" H
1	BD36	Contoured bin unit, 5 shelves w/bins, 36" W x 40" H
1	6404	Shelving install track kit, driver side
1	6405	Shelving install track kit, passenger side

W116 P 10 DELUXE SERVICE PACKAGE ALUMINUM 110 lbs



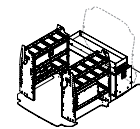
1	SD60-3	Contoured shelf unit, 3 shelves, 60" W x 40" H
2	6070	6" Hook, 3" opening
1	5070	Partskeeper carry case w/holder, 14" D x 17" W x 5½" H
1	BD36	Contoured bin unit, 5 shelves w/bins, 36" W x 40" H
1	6403	Shelving install track kit, driver side
1	6405	Shelving install track kit, passenger side

W011 P 13 BASE ELECTRICAL PACKAGE ALUMINUM 121 lbs



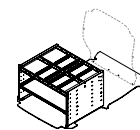
2	SD36-3	Contoured shelf unit, 3 shelves, 36" W x 40" H
1	6070	6" Hook, 3" opening
1	6072	8" Swivel Hook, 4" opening
1	5069-2	2 Drawer cabinet, 150 lb cap./drawer, 14" D x 24" W x 12" H
1	7728	Locking door, 32 7/8" W x 10 3/8" H
1	5070	Partskeeper carry case w/holder, 14" D x 17" W x 5½" H
1	6404	Shelving install track kit, driver side
1	6405	Shelving install track kit, passenger side

W111 P 14 DELUXE ELECTRICAL PACKAGE ALUMINUM 202 lbs



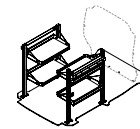
2	SD36-3	Contoured shelf unit, 3 shelves, 36" W x 40" H
1	6070	6" Hook, 3" opening
1	6072	8" Swivel Hook, 4" opening
1	5069-2	2 Drawer cabinet, 150 lb cap./drawer, 14" D x 24" W x 12" H
1	7728	Locking door, 32 7/8" W x 10 3/8" H
1	5070	Partskeeper carry case w/holder, 14" D x 17" W x 5½" H
1	5020	Tool drawer, 320 lbs capacity, 48" D x 14" W x 16" H
1	5010	Partslider drawer, 150 lbs capacity, 48" D x 12" W x 6" H
1	5048	Top edge, for 5010 Partslider
1	6404	Shelving install track kit, driver side
1	6405	Shelving install track kit, passenger side

W019 P 17 BASE DELIVERY PACKAGE ALUMINUM 89 lbs



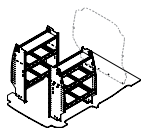
1	5032-1	Axess Tray with 1 shelf / 1 drawer, 38" D x 45" W x 30" H
1	6471	Axess Tray install track kit

W119 P 18 DELUXE DELIVERY PACKAGE ALUMINUM 90 lbs



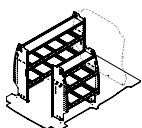
2	8330-2	Fold-Away shelving unit, 2 levels, 18" D x 37" W x 46 1/2" H
1	84-7107	Fold-Away shelving install kit, driver side
1	84-7108	Fold-Away shelving install kit, passenger side

Z10-BW P5 BASE CONTRACTOR PACKAGE STEEL 106 lbs



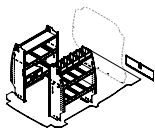
2	F32-W	Contoured shelving unit, 1 open & 2 divided shelves, 32" W
2	Y30-C	Coat Hook, 1" opening
1	6410	Shelving install track kit, 32" L units, passenger side
1	6411	Shelving install track kit, 32" L units, driver side

Z10-DW P6 DELUXE CONTRACTOR PACKAGE STEEL 119 lbs



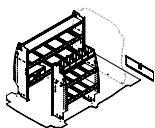
1	F56-W	Contoured shelving unit, 1 open & 2 divided shelves, 56" W
1	F32-W	Contoured shelving unit, 1 open & 2 divided shelves, 32" W
2	Y30-C	Coat Hook, 1" opening
1	6406	Shelving install track kit, driver side
1	6410	Shelving install track kit, 32" L units, passenger side

Z16-BW P9 BASE SERVICE PACKAGE STEEL 123 lbs



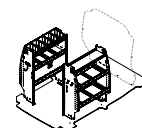
1	H32-W	Contoured shelving unit, 1 bin & 2 divided shelves & a door, 32" W
1	F32-W	Contoured shelving unit, 1 open & 2 divided shelves, 32" W
2	Y30-C	Coat Hook, 1" opening
1	5070	Partskeeper carry case w/holder, 14" D x 17" W x 5½" H
1	6410	Shelving install track kit, 32" L units, passenger side
1	6411	Shelving install track kit, 32" L units, driver side

Z16-DW P10 DELUXE SERVICE PACKAGE STEEL 136 lbs



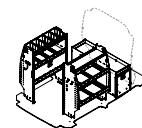
1	F56-W	Contoured shelving unit, 1 open & 2 divided shelves, 56" W
1	H32-W	Contoured shelving unit, 1 bin & 2 divided shelves & a door, 32" W
2	Y30-C	Coat Hook, 1" opening
1	5070	Partskeeper carry case w/holder, 14" D x 17" W x 5½" H
1	6406	Shelving install track kit, driver side
1	6410	Shelving install track kit, 32" L units, passenger side

Z11-BW P13 BASE ELECTRICAL PACKAGE STEEL 116 lbs



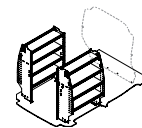
1	H32-W	Contoured shelving unit, 1 bin & 2 divided shelves & a door, 32" W
1	F32-W	Contoured shelving unit, 1 open & 2 divided shelves, 32" W
1	6070	6" Hook, 3" opening
2	Y30-C	Coat Hook, 1" opening
1	6410	Shelving install track kit, 32" L units, passenger side
1	6411	Shelving install track kit, 32" L units, driver side

Z11-DW P14 DELUXE ELECTRICAL PACKAGE STEEL 196 lbs



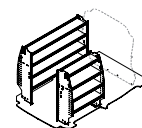
1	H32-W	Contoured shelving unit, 1 bin & 2 divided shelves & a door, 32" W
1	F32-W	Contoured shelving unit, 1 open & 2 divided shelves, 32" W
1	6070	6" Hook, 3" opening
2	Y30-C	Coat Hook, 1" opening
1	X02-A	Fleetline Tool Drawer, 45½" D x 13½" W x 22" H
1	6410	Shelving install track kit, 32" L units, passenger side
1	6411	Shelving install track kit, 32" L units, driver side

Z19-BW P17 BASE DELIVERY PACKAGE STEEL 122 lbs



2	L32-W	Contoured shelving unit, 4 open shelves, 32" W
2	Y30-C	Coat Hook, 1" opening
1	6410	Shelving install track kit, 32" L units, passenger side
1	6411	Shelving install track kit, 32" L units, driver side

Z19-DW P18 DELUXE DELIVERY PACKAGE STEEL 139 lbs

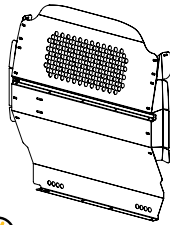


1	L56-W	Contoured shelving unit, 4 open shelves, 56" W
1	L32-W	Contoured shelving unit, 4 open shelves, 32" W
2	Y30-C	Coat Hook, 1" opening
1	6406	Shelving install track kit, driver side
1	6410	Shelving install track kit, 32" L units, passenger side

ADDITIONAL PRODUCTS

CHOOSE YOUR PARTITION!

CONTOURED SAFETY PARTITION
PERFORATED WINDOW
Steel



C10-W

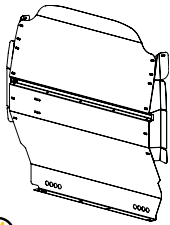


53 lbs



1 hr

CONTOURED SAFETY PARTITION
Steel



C12-W

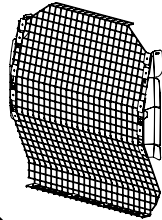


53 lbs



1 hr

CONTOURED SAFETY PARTITION
WIRE MESH
Steel



C13-W

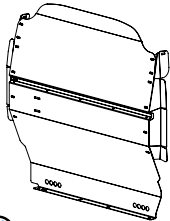


27 lbs



0.7 hr

CONTOURED SAFETY PARTITION
Aluminum



3010-NS

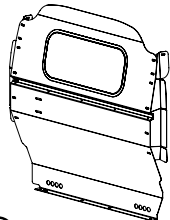


42 lbs



1 hr

CONTOURED PARTITION
TEMPERED GLASS WINDOW
Aluminum



3020-NS



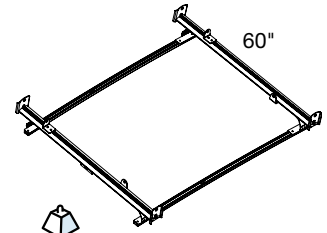
42 lbs



1 hr

CHOOSE YOUR LADDER RACK!

CARGO RACK
2 BAR
Aluminum



1505-NS



480 lbs

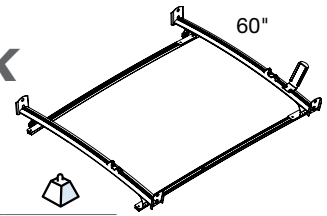


0.8 hr



18 lbs

STANDARD LADDER RACK
2 BAR
Aluminum



1510-NS



400 lbs

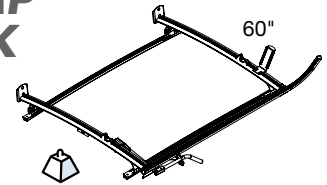


0.9 hr



18 lbs

SINGLE CLAMP LADDER RACK
2 BAR
Aluminum



1520-NS



400 lbs

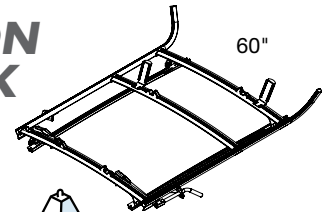


1.2 hr



28 lbs

COMBINATION LADDER RACK
2 BAR
Aluminum



1525-NS



400 lbs

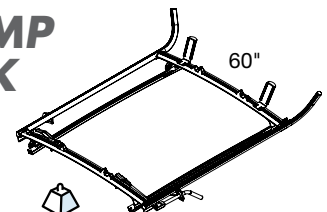


1.7 hr



43 lbs

DOUBLE CLAMP LADDER RACK
2 BAR
Aluminum



1530-NS



400 lbs



1.7 hr



36 lbs

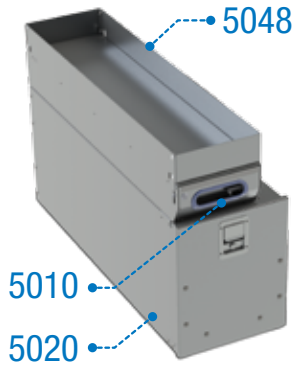
LEGEND

DIMENSIONS

WEIGHT CAPACITY

WEIGHT

ADDITIONAL PRODUCTS



5010
PARTSLIDER
DRAWER
Aluminum

48" D x 12" W x 6" H
150 lbs
0.5 hr
30 lbs

5020
TOOL
DRAWER
Aluminum

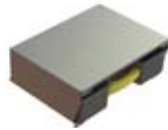
48" D x 14" W x 16" H
320 lbs
1 hr
46 lbs

5048
TOP EDGE
Aluminum
(for 5010 Partslider)

48" D x 12" W x 4" H
0.2 hr
5 lbs

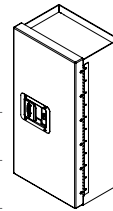
5070
PARTSKEEPER CARRY CASE
WITH ALUMINUM HOLDER
Universal Mount

14"W x 17"W x 5.5"H
0.5 hr
7 lbs



6040
LOCKING
CABINET
Aluminum

8.5"D x 12"W x 24"H
0.6 hr
16 lbs



6041
LOCKING
CABINET
Aluminum

15"D x 15.5"W x 33"H
0.7 hr
26 lbs



6061
2-SLOT DEEP
PAPER HOLDER
Aluminum

3.75"D x 12.75"W x 12"H
0.2 hr
2 lbs



6070
6" HOOK
WITH 3" OPENING
Powder Coated Steel

0.2 hr
1 lb



6072
8" SWIVEL HOOK
WITH 4" OPENING
Powder Coated Steel

0.2 hr
1 lb



6086
SMALL BOTTLE HOLDER
Aluminum
(Includes one 36" blue nylon strap)

6" D x 12" H
0.2 hr
1 lb



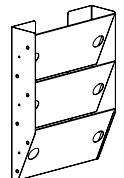
6088
LARGE BOTTLE HOLDER
Aluminum
(Includes two 36" blue nylon straps)

8" W x 24" H
0.2 hr
2 lbs



Y31-A
3-SLOT DEEP
PAPER HOLDER
Steel

3.75"D x 12.75"W x 16"H
0.2 hr
9 lbs



Y35-B
MEDIUM BIN
Plastic

10" D x 6" W x 4.5" H



Y35-D
LARGE BIN
Plastic

14" D x 8" W x 5.5" H



INSTALL TIME

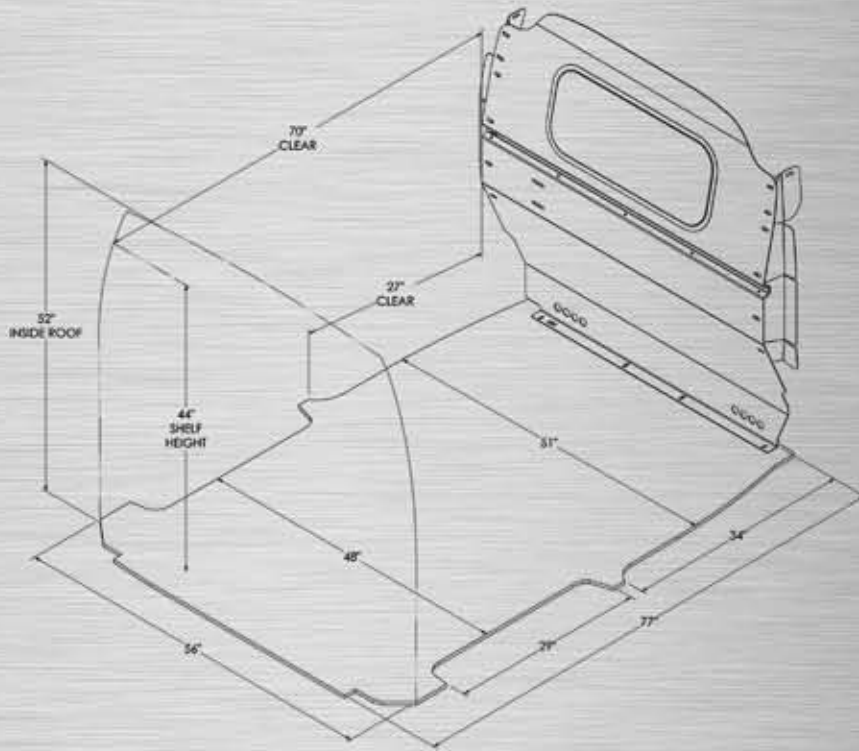
SHELF OPENING

WHEELBASE

ROOF HEIGHT



THE PERFECT FIT FOR YOUR TOUGHEST JOBS



CUSTOMER SERVICE
cs@rangerdesigninc.com
1 (800) 565-5321
www.rangerdesign.com
info@rangerdesign.com



YOUR LOCAL DEALER

M110-138 V1