



PTN SERIES

MEDIUM DUTY RAIL GATE

1,250 lb. and 1,600 lb. Capacities

**The Strongest, Most Durable
Liftgate for Transporting Bulky,
Top-Heavy Loads.**

Products shown may feature optional equipment.
Content subject to change without notice.



Optional Aluminum Platform Shown



STANDARD PTN SERIES ADVANTAGES INCLUDE:

- Applications - pickup trucks and cargo vans
- Gate is level with truck side panels (photo)
- Safer: – level-ride, greater load stability
– fewer pinch points
– anti-skid steel treadplate platform
- Exclusive above floor lift option with a maximum above floor travel of 9"
- Chain and sprocket drive ensures smooth operation and eliminates costly cable replacement
- Platform side chains eliminated – user has unimpeded side access
- Existing receiver style hitch won't impede installation - most models
- UHMW - slide pads on runners

OTHER STANDARD FEATURES:

- Power unit installed, tested and enclosed in weather protected housing
- Torsion bar assisted platform makes it easier to open and close
- Pressure compensated flow control valve controls platform descent regardless of load weight
- Built-in toe deflector
- Weather sealed controls
- Charge line circuit protection
- Meets TMC specifications
- Powder coat finish on key liftgate components produces a high-quality finish that is exceptionally resistant to corrosion and abrasion

**Exclusive above floor lift option will reach
most dock heights**



**PTN Series Gate in stowed position with
the optional aluminum platform**

PTN SERIES

MEDIUM DUTY RAIL GATE

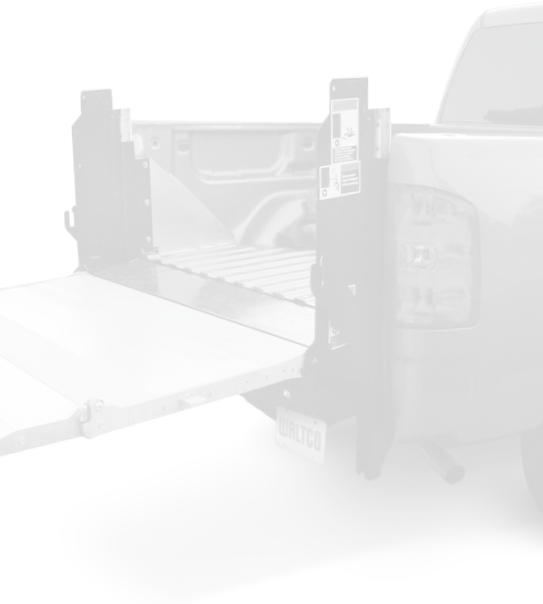

SPECIFICATIONS

Bed Ht: 25" - 38"

MODEL	CAPACITY	PLATFORM	RAMP
PTN-12	1,250 lbs.	24" x 57"	6"
PTN-12	1,250 lbs.	30" x 57"	6"
PTN-12	1,250 lbs.	36" x 57"	6"
PTN-16	1600 lbs.	30" x 57"	6"
PTN-16	1600 lbs.	36" x 57"	6"
PTN-16	1600 lbs.	42" x 57"	6"
AP (Aluminum Platform)			
PTN/AP-12	1,250 lbs.	24" x 57"	8"
PTN/AP-12	1,250 lbs.	38" x 57"	8"
PTN/AP-16	1,600 lbs.	38" x 57"	8"
PTN/AP-16	1,600 lbs.	44" x 57"	8"

Note: Above floor models are available for 25" - 46" bed heights with a maximum above floor travel of 9".

OPTIONAL EQUIPMENT:

- Platform Material:
 - Aluminum
 - Expanded Metal
 - Bar Grating
- Above floor lift raises platform with a maximum above floor travel of 9"
- Oversized Ramp in aluminum or steel:
 - Fixed
 - Hinged
 - With Cart Stop
- Non-standard liftgates, deeper, narrower or wider platforms
- Remote hand held toggle switch control with 15 ft. coil cord
- Hydraulic platform closing
- Customized Options - contact factory

WALTCO

T: 800.211.3074
F: 800.211.3075
Email: sales@waltco.com
Web: www.waltcoliftgates.com

Waltco Lift Corp.
Corporate Office United States
285 Northeast Ave.
Tallmadge, OH 44278
P: 330.633.9191
F: 330.633.1418

Waltco Lift Corp.
United States
620 S Hambledon Ave.
City of Industry, CA 91744
P: 626.964.0990
F: 626.964.0149

Waltco Lift Inc.
Canada
90 North Queen St.
Etobicoke, ON M8Z 2C5